

Contents

Dry Compressing Vacuum Pumps

Global Versions

Diaphragm Vacuum Pumps **DIVAC** 217

General

DIVAC Program Overview. 217

The customized Diaphragm Pump and the Accessories recommended for your Applications 218

Modular Diaphragm Pump System for the Chemical Laboratory 219

Products

Diaphragm Vacuum Pumps for the Chemical Laboratory 220

Dual-Stage Diaphragm Vacuum Pumps

DIVAC 0.6 L, 1.2 L, 2.2 L 220

Three-Stage Diaphragm Vacuum Pumps

DIVAC 1.4 HV3C 222

Dry Compressing Backing Pumps for Turbomolecular Pumps 224

DIVAC 0.8 T and 0.8 LT 226

DIVAC 1.4 HV3 and 3.8 HV3. 228

DIVAC 4.8 VT 230

Scroll Vacuum Pumps **SCROLLVAC** 232

General

Applications and Accessories for SCROLLVAC Pumps 232

Products

Oil-free Scroll Vacuum Pumps SCROLLVAC SC 5 D to SC 60 D. 233

Screw Vacuum Pumps **LEYVAC** 239

General

Applications for LEYVAC Pumps 239

General 240

Products

LEYVAC LV 80 to LV 140 C 242

Screw Vacuum Pumps SCREWLINE. 245

General

Applications for SCREWLINE Pumps 245
General SCREWLINE SP 250 to SP 630 (F) 246

Products

SCREWLINE SP 250 250
SCREWLINE SP 630 252

Screw Vacuum Pumps DRYVAC 256

General

Applications for DRYVAC Pumps 256
Oil for DRYVAC pumps, for different fields of application 257
Oil for DRYVAC pumps, for different pump types 258
General DRYVAC DV 450 to DVR 5000 C-i 259

Products

DRYVAC DV / DV S / DV C 268

Versions for the North and South American Continents

**Dry Vacuum Pumps CHEMROVAC TRV
for Chemical and Pharmaceutical Applications 272**

General

Applications for CHEMROVAC Pumps 272

Products

CHEMROVAC TRV 404 to 410 274

DIVAC Program Overview

This range of vacuum pumps was developed especially for laboratory operations and as backing pumps for (wide range) turbomolecular pumps. It satisfies the highest expectations in terms of precision, reliability and ease of use.

The DIVAC line of vacuum pumps is the logical continuation of diaphragm pump technology which has proven its quality in decades of service.

Laboratory Pumps

Through the laboratory pumps and the three different pumping speeds available for the same base pressure and through the modular design, the optimum pump system can be implemented for every application.

DIVAC L diaphragm pumps are suited for almost all requirements in the chemistry lab. They are basically corrosion and solvent resistant since their parts in contact with the pumped medium are made of PTFE (Teflon), FFPM (Kalrez) and PVDF (Solef).

Backing Pumps

The DIVAC T range of diaphragm pumps comprises backing pumps which are used in all applications requiring an especially low base pressure while having to maintain an oil-free vacuum.

The DIVAC T pumps have been specially developed as backing pumps for wide range high vacuum turbomolecular pumps. They meet the requirements for a dry vacuum and a long service life.

DIVAC T pumps may be used both free-standing and integrated in applications or certain devices, and for this reason they are used in the areas of mass spectrometry, analytical and in general applications.

Application Examples

Laboratory Pumps

- Vacuum filtration
- Vacuum distillation
- Vacuum drying
- To extract and transfer gases
- On rotary evaporators
- Gel drying

Backing Pumps

- Backing pump for wide range turbomolecular pumps
- Mass spectrometry
- Medicine technology
- Analytical technology
- General rough and medium vacuum applications

The customized Diaphragm Pump and the Accessories recommended for your Applications

	Modular diaphragm pump system	Evacuating small devices (e.g. desiccator)	Sublimation	Analysis preparation	Filtration	Distillation	Drying in the drying cabinet	Drying cabinets (2 cabinets)	Rotary evaporator	Backing pumps for wide range turbomolecular pumps	Mass spectrometry	Medical technology	Analytical technology	General applications in the rough and medium vacuum range
Application														
DIVAC 0.6 L	■	■	■	■	■									■
DIVAC 1.2 L	■	■	■	■	■			■						■
DIVAC 2.2 L	■	■	■	■	■	■	■	■						■
DIVAC 1.4 HV3C	■	■	■	■	■	■	■	■	■	■	■	■	■	■
DIVAC 0.8 T									■	■	■	■	■	
DIVAC 0.8 TL									■	■	■	■	■	
DIVAC 1.4 HV3									■	■	■	■	■	
DIVAC 3.8 HV3									■	■	■	■	■	
DIVAC 4.8 VT									■	■	■	■	■	

Modular Diaphragm Pump System for the Chemical Laboratory

Advantages to the User

- Low base vacuum of 8 mbar (6 Torr) for two-stage and 2 mbar (1.5 Torr) for three-stage DIVAC
- All parts of the pump head in contact with the gas are resistant against aggressive media through the use of PTFE (Teflon), FFPM (Kalrez) and PVDF (Solef)
- Dry compressing, oil-free
- Water vapor tolerance
- Low maintenance costs and long service intervals through the use of high-quality components which are well-proven
- Simple maintenance by staff of the customer
- Low noise operation
- Portable, compact, small footprint
- Can be operated in any orientation
- Overheat protection for the vacuum pump by means of a thermal fuse
- Available in four pumping speed categories

Products

Diaphragm Vacuum Pumps for the Chemical Laboratory

Dual-Stage Diaphragm Vacuum Pumps

DIVAC 0.6 L, 1.2 L, 2.2 L

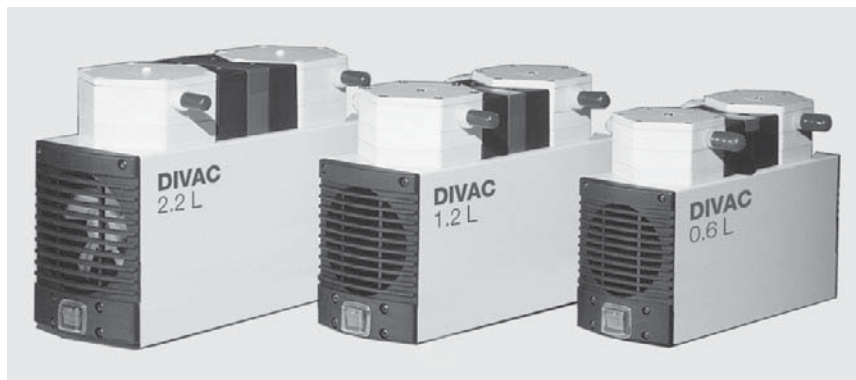

Typical Applications

Vacuum generation for

- Rotary evaporators
- Drying chambers
- Filtration units
- Distillation configurations
- Gel dryers

Dual-stage diaphragm vacuum pumps DIVAC 0.6 L, 1.2 L, 2.2 L

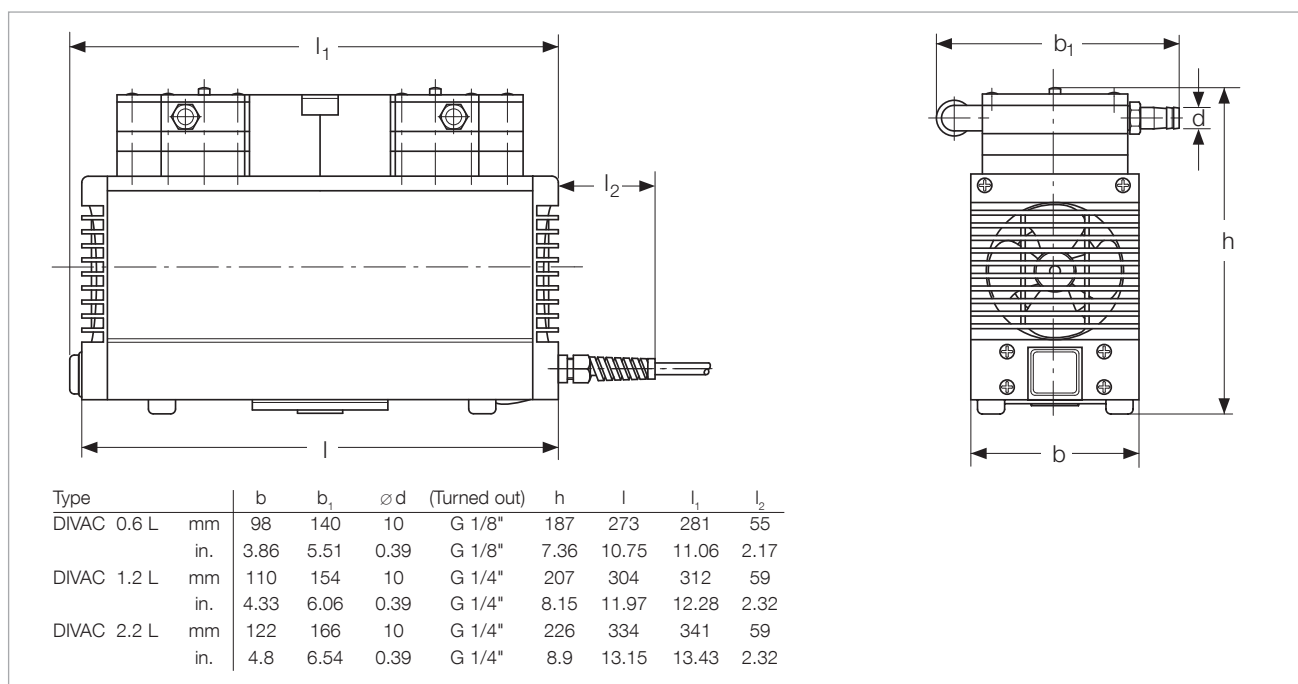

Dimensional drawing for the DIVAC 0.6 L, 1.2 L, 2.2 L

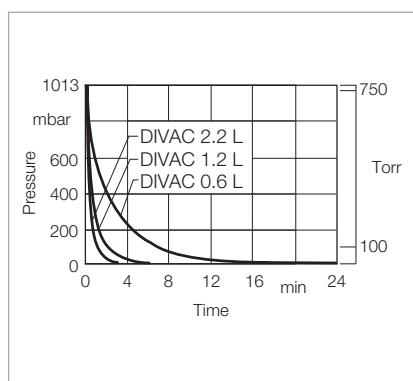

Curves of pump-down time of a 10 l vessel

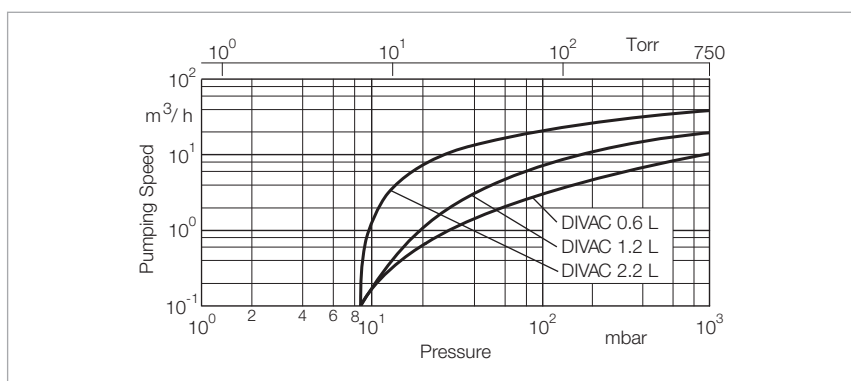

Curves of pumping capacity

Technical Data

		DIVAC		
		0.6 L	1.2 L	2.2 L
Max. pumping speed (atm.)	m ³ x h ⁻¹ (cfm)	0.6 (0.4)	1.2 (0.7)	2.0 (1.2)
Ultimate pressure	mbar (Torr)	≤ 8 (≤ 6)	≤ 8 (≤ 6)	≤ 8 (≤ 6)
Max. exhaust back pressure (absolute)	mbar (Torr)	2000 (1500)	2000 (1500)	2000 (1500)
Pump heads		2	2	2
Connection				
Inlet (suction side)		Hose nozzle ID 10	Hose nozzle ID 10	Hose nozzle ID 10
Exhaust (delivery side)		Hose nozzle ID 10	Hose nozzle ID 10	Hose nozzle ID 10
Thread (suction and delivery side)	G	G 1/8"	G 1/4"	G 1/4"
Noise level acc. to DIN 45 635 Part 13, approx.	dB(A)	47	50	52
Permissible gas admission temperature, max.	°C (°F)	+5 to +40 (+41 to +104)	+5 to +40 (+41 to +104)	+5 to +40 (+41 to +104)
Permissible ambient temperature, max.	°C (°F)	+5 to +40 (+41 to +104)	+5 to +40 (+41 to +104)	+5 to +40 (+41 to +104)
Voltage / nominal frequency (1-ph. motor)				
Schuko plug	V / Hz	230 ± 10% / 50	230 ± 10% / 50	230 ± 10% / 50
NEMA plug	V / Hz	115 ± 10% / 60	115 ± 10% / 60	115 ± 10% / 60
NEMA plug	V / Hz	100 ± 10% / 50/60	100 ± 10% / 50/60	100 ± 10% / 50/60
Protective class	IP	44	44	44
Motor power ¹⁾	W	90	120	245
Current consumption ¹⁾	A	0.6	0.7	1.8
Motor speed				
50 Hz	min ⁻¹	1500	1500	1500
60 Hz	min ⁻¹	1800	1800	1800
Dimensions (W ¹⁾ x H ¹⁾ x D), approx.	mm (in.)	281 x 140 x 187 (11.06 x 5.51 x 7.36)	312 x 154 x 207 (12.28 x 6.06 x 8.15)	341 x 166 x 226 (13.43 x 6.54 x 8.9)
Weight, approx.	kg (lbs)	6.9 (15.2)	9.3 (20.5)	12.6 (27.8)
Material				
Pump head		PTFE (Teflon)	PTFE (Teflon)	PTFE (Teflon)
Structured diaphragm		PTFE coated	PTFE coated	PTFE coated
Valves		FFPM (Kalrez)	FFPM (Kalrez)	FFPM (Kalrez)
Nozzles		PVDF (Solef)	PVDF (Solef)	PVDF (Solef)

Ordering Information

		DIVAC		
		0.6 L	1.2 L	2.2 L
		Part No.	Part No.	Part No.
Diaphragm vacuum pump 230 V, 50 Hz, with 2.3 m (8 ft) power cord and Schuko plug		135 00	135 06	135 12
Diaphragm vacuum pump 230 V, 50/60 Hz, with 2.3 m (8 ft) power cord and Schuko plug		-	-	135 11
Diaphragm vacuum pump 100 V, 50/60 Hz, with 2.3 m (8 ft) power cord and NEMA plug		135 02	135 08	135 14
Diaphragm vacuum pump 115 V, 60 Hz, with 2.3 m (8 ft) power cord and NEMA plug		135 03	135 09	135 15
Spare parts kit consisting of 2 diaphragms, 4 gasket rings, 4 valve plates		EK 135 23	EK 135 24	EK 135 25
Hose nozzle kit consisting of 2 hose nipples, piping		-	200 65 006	200 65 007

¹⁾ For 230 V, 50 Hz version

Three-Stage Diaphragm Vacuum Pumps DIVAC 1.4 HV3C



Three-stage diaphragm vacuum pump DIVAC 1.4 HV3C

The DIVAC 1.4 HV3C is a three-stage diaphragm pump capable of resisting chemicals and offering an improved pumping performance. Its speed is infinitely variable from 700 to 1600 rpm so that the pumping speed of the pump can be easily adapted to differing requirements. The built-in textured diaphragm is made of EPDM and has been coated with PTFE. The valves are made of KALREZ® thereby ensuring excellent resistance also in connection with aggressive gases. Owing to the three-stage design, pressures of 2 mbar can be attained very easily.

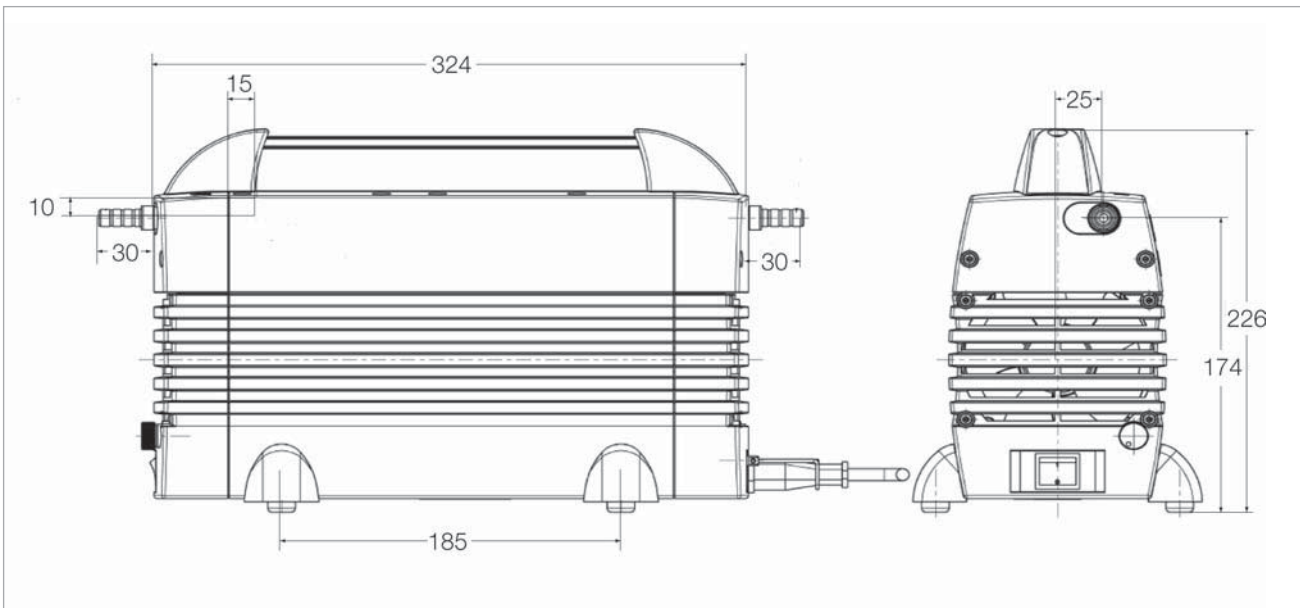

Dimensional drawing for the DIVAC 1.4 HV3C

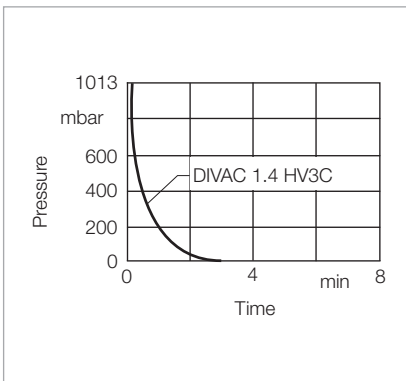

Curves of pump-down time of a 10 l vessel

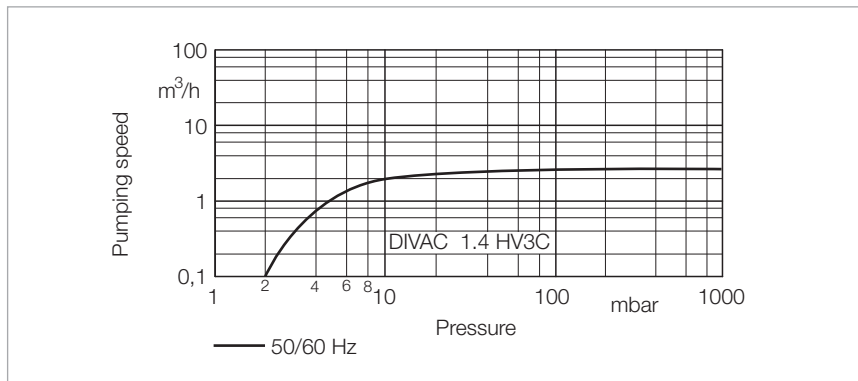

Curves of pumping capacity

Technical Data
DIVAC 1.4 HV3C

Max. pumping speed	m ³ x h ⁻¹ (cfm)	1.3 (0.77)
Ultimate pressure	mbar (Torr)	≤ 2.0 (≤ 1.5)
Max. exhaust back pressure (absolute)	mbar (Torr)	1500 (1125)
Pump heads		3
Connection		
Inlet (suction side)	DN	Hose nozzle ID 10
Exhaust (delivery side)	DN	Hose nozzle ID 10
Thread (suction and delivery side)	G	G 1/8"
Noise level acc. to DIN 45 635 Part 13, approx.	dB(A)	48
Permissible gas admission temperature	°C (°F)	+5 to +40 (+41 to +104)
Permissible ambient temperature	°C (°F)	+5 to +40 (+41 to +104)
Voltage / nominal frequency	V / Hz	90-230 / 50-60
Protective class	IP	20
Motor power ¹⁾	W	135
at ultimate pressure	W	35
Current consumption ¹⁾	A	1.3
Motor speed	min ⁻¹	700 to 1600
Dimensions (W x H x D), approx.	mm (in.)	324 x 158 x 226 (12.76 x 6.22 x 8.90)
Weight, approx.	kg (lbs)	8.6 (18.99)
Material		
Pump head		Ryton
Structured diaphragm		EPDM coated with PTFE
Valves		FFPM (Kalrez)
Nozzles		PTFE

Ordering Information
DIVAC 1.4 HV3C

	Part No.
Diaphragm vacuum pump 90-230 V, 50-60 Hz, with 2.3 m (8 ft) power cord and Schuko plug	135 20 V
Accessories Exhaust silencer 1.4 with connection G 1/8"	127 90 A

¹⁾ For 230 V, 50 Hz version

Dry Compressing Backing Pumps for Turbomolecular Pumps

DIVAC 0.8 T to 4.8 VT

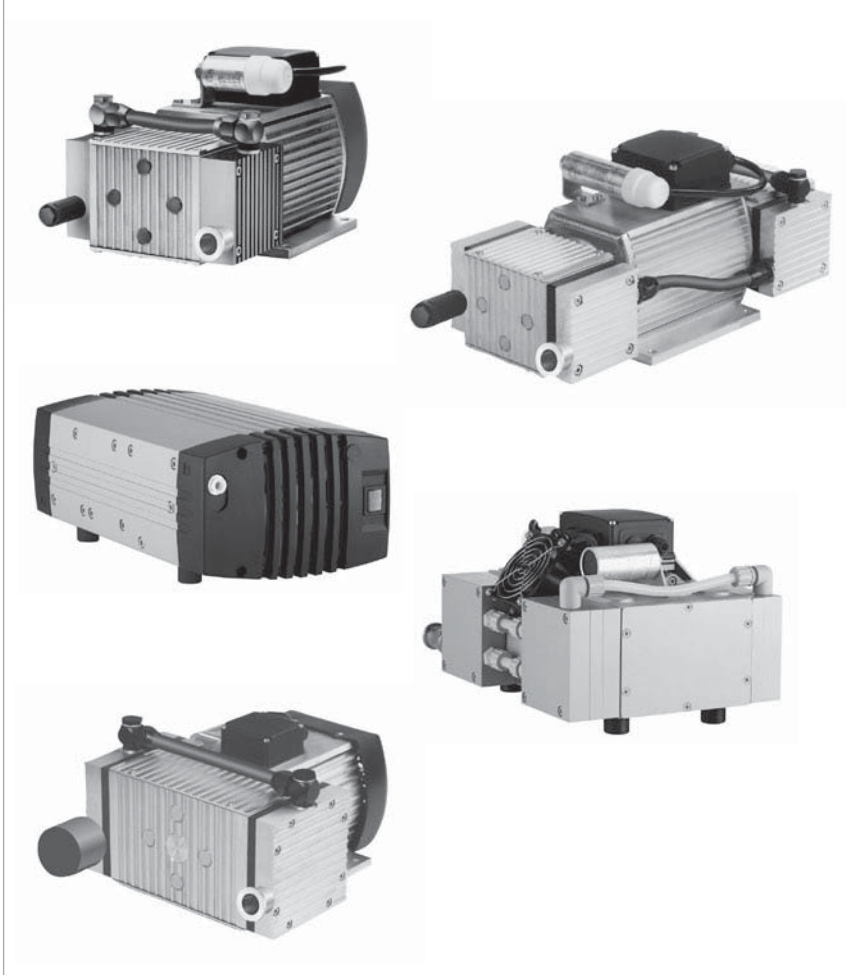

Our dry compressing backing pumps from the DIVAC T series are now supplemented by the three-stage DIVAC 1.4 HV3 and the DIVAC 3.8 HV3. Like the proven DIVAC T series, these new models also ensure a forevacuum free of hydrocarbons. Owing to their three-stage design, they provide especially within the lower pressure ranges a higher pumping speed and are therefore even better suited as backing pumps for turbomolecular pumps. But they are also used as backing pumps operating in the rough and medium vacuum range to pump clean media.

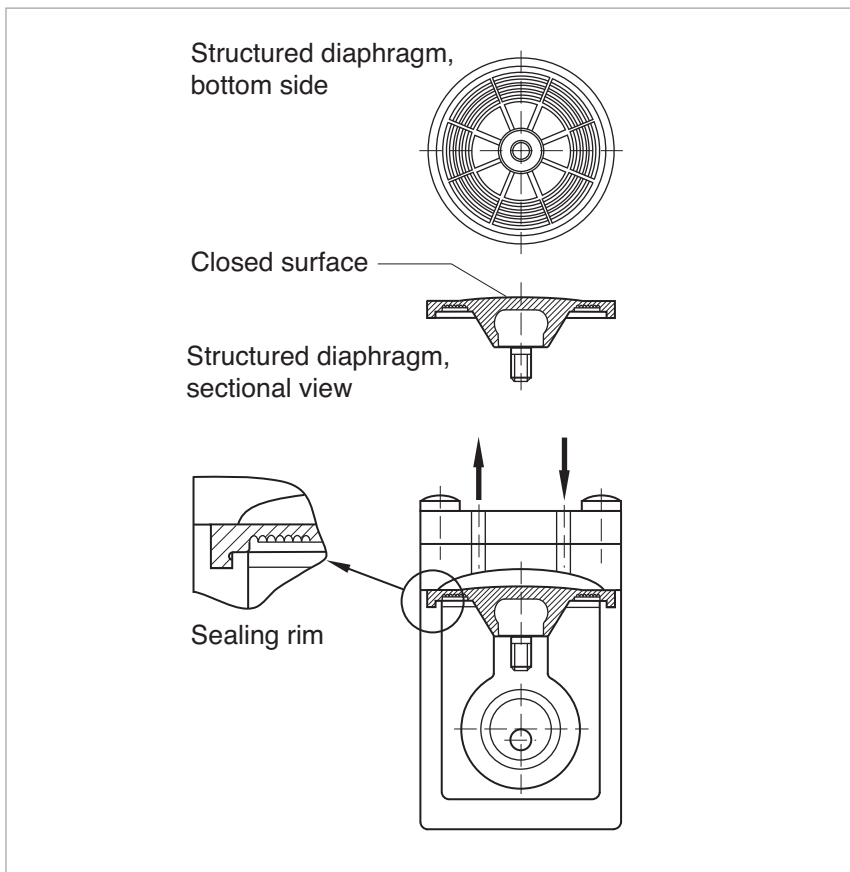

Diaphragm pump with structured diaphragm

The structured diaphragm with its sealed surface provides the basis for a long service life and a low base pressure.

Advantages to the User

- Dry compressing, free of oil and hydro-carbons
- Matched to the turbomolecular pumps from Oerlikon Leybold Vacuum (SL 80 to TURBOVAC 450i)
- Low ultimate pressure
- ISO-KF flange at the intake port
- Fully equipped with cable, switch (ON/OFF) and plug
- Better performance and smaller size through the use of structured diaphragms
- Low vibration levels through dynamic mass balancing (in VT pumps)
- Lower maintenance costs and long maintenance intervals through the use of high-quality and well-proven components
- Simple maintenance
- Favourable price-to-performance ratio
- Can be operated in any position

Typical Applications

- Backing pump for wide pressure range turbomolecular pumps
- Mass spectrometers
- Medical equipment
- Analyzes
- For laboratory applications also with corrosive media
- General use for rough and fine vacuum applications

DIVAC 0.8 T and 0.8 LT

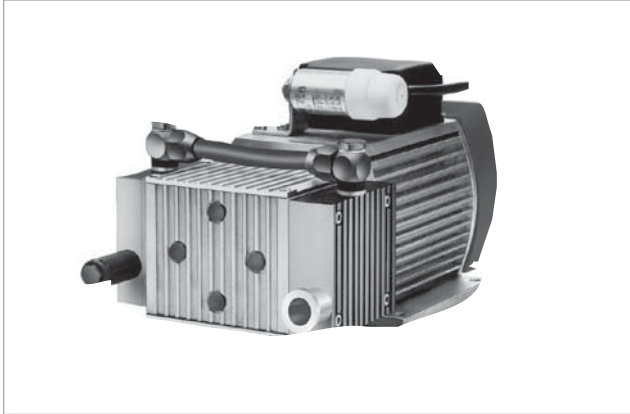

DIVAC 0.8 T

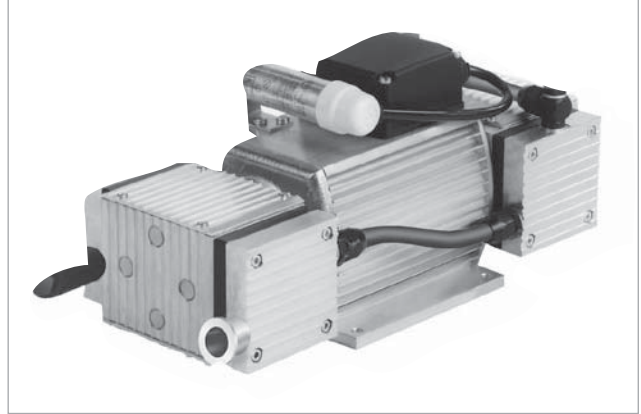

DIVAC 0.8 LT

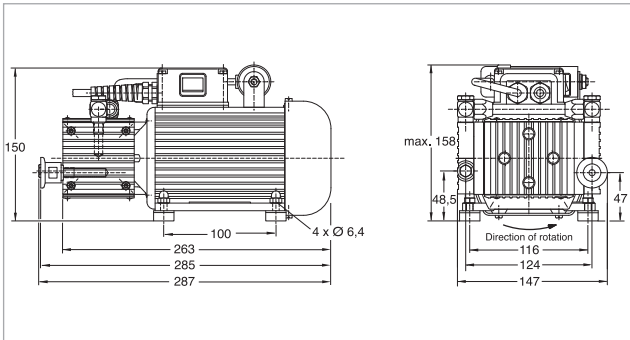

Dimensional drawing for the DIVAC 0.8 T

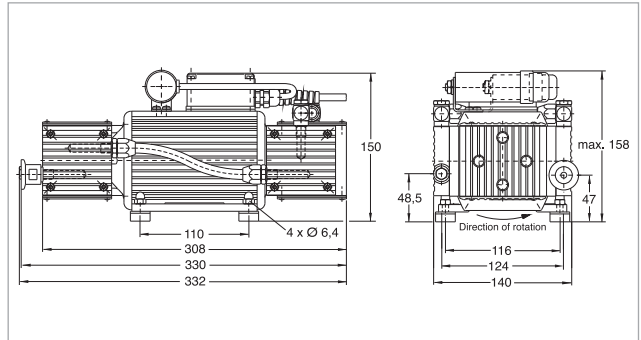

Dimensional drawing for the DIVAC 0.8 LT

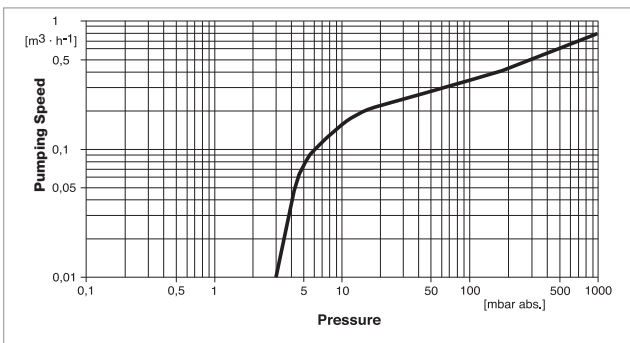

Pumping speed curve of the DIVAC 0.8 T

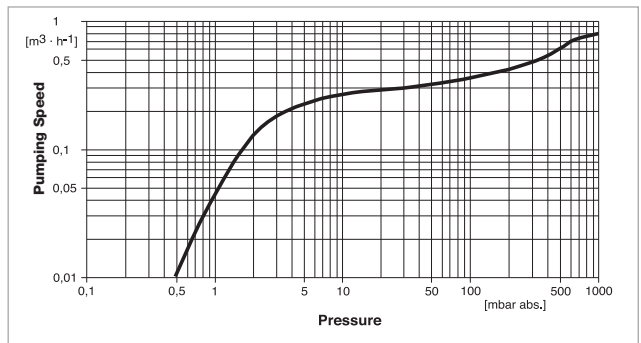

Pumping speed curve of the DIVAC 0.8 LT

Technical Data
DIVAC

		0.8 T	0.8 LT
Max. pumping speed (atm.)	m ³ /h (cfm)	0.77 (0.45)	0.77 (0.45)
Ultimate pressure (absolute)	mbar (Torr)	≤ 3.0 (≤ 2.25)	≤ 0.5 (≤ 0.38)
Max. exhaust back pressure (absolute)	mbar (Torr)	2000 (1500)	2000 (1500)
Pump heads		2	4
Connection			
Inlet (suction side)	DN	16 KF	16 KF
Exhaust (delivery side)	DN	Silencer	Silencer
Thread (suction and delivery side)		G 1/8"	G 1/8"
Noise level acc. to DIN 45 635 Part 13, approx.	dB(A)	49	53
Permissible gas admission temperature	°C (°F)	+5 to +40 (+41 to +104)	+5 to +40 (+41 to +104)
Permissible ambient temperature	°C (°F)	+5 to +40 (+41 to +104)	+5 to +40 (+41 to +104)
Voltage / nominal frequency (1-ph. motor)			
Schuko plug	V / Hz	198-264 / 50/60	230 / 50 ± 10%
NEMA plug	V / Hz	90-127 / 50/60	115 / 60 ± 10%
Protective class	IP	44	44
Motor power	W	50	80
Current consumption	A	0.4	0.5
Nominal speed, approx. (50/60 Hz)	min ⁻¹	1500/1800	1500/1800
Dimensions (W x H x D), approx.	mm (in.)	285 x 150 x 150 (11.22 x 5.9 x 5.9)	332 x 150 x 150 (13.07 x 5.9 x 5.9)
Weight, approx.	kg (lbs)	5.9 (13.02)	7.5 (16.56)
Material			
Diaphragm		Neoprene	Neoprene
Valves		EPDM	EPDM
Pump head		Aluminum	Aluminum

Ordering Information
DIVAC

	0.8 T	0.8 LT
	Part No.	Part No.
Diaphragm vacuum backing pumps for turbomolecular pumps including 1 m (3.5 ft) long mains cord, country-specific plug, silencer, rubber feet, as well as ON/OFF switch 198-264 V / 50/60 Hz 230 V / 50 Hz ± 10%	127 80 -	- 127 83
Spare parts kit consisting of 2 diaphragms, 4 valves, 4 valve gaskets, 4 piping gaskets	EK 127 95	EK 127 95 (2x)
Exhaust silencer	127 98	127 98

T = For use in connection with Turbomolecular pumps

L = Very low ultimate pressure (Low pressure)

V = Low vibration levels (Low Vibration)

DIVAC 1.4 HV3 and 3.8 HV3



DIVAC 1.4 HV3



DIVAC 3.8 HV3

The three-stage DIVAC 1.4 HV3 and the DIVAC 3.8 HV3 provide especially in the lower pressure range a higher pumping speed compared to conventional diaphragm pumps. At the same time they are capable of attaining ultimate pressures below 2 mbar (1.5 Torr) and are thus very well suited as backing pumps for turbomolecular pumps. Owing to their compact design they are also suited for installation within pump systems.

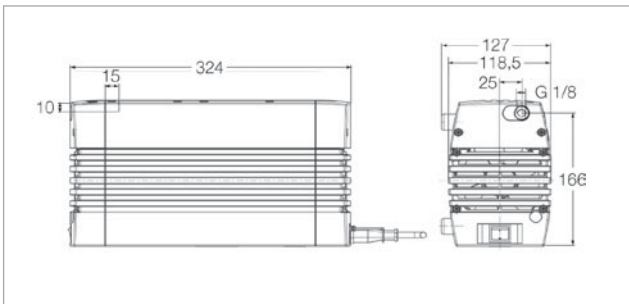

Dimensional drawing for the DIVAC 1.4 HV3

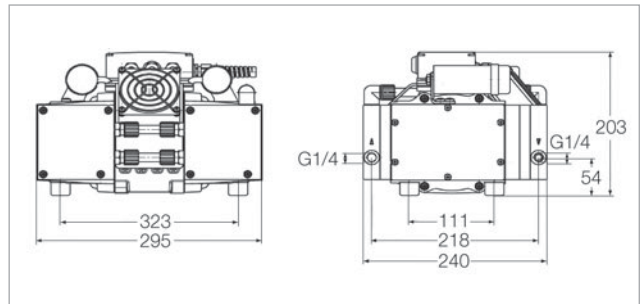

Dimensional drawing for the DIVAC 3.8 HV3

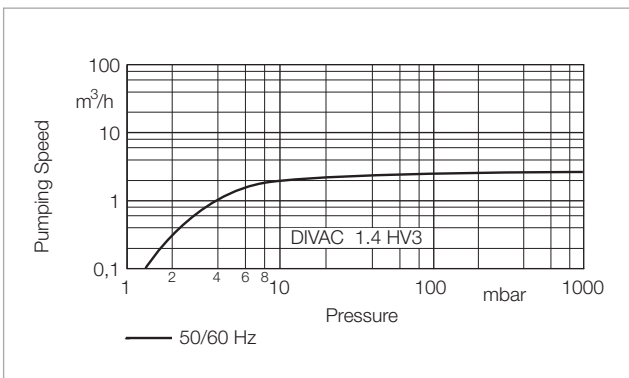

Pumping speed curve of the DIVAC 1.4 HV3

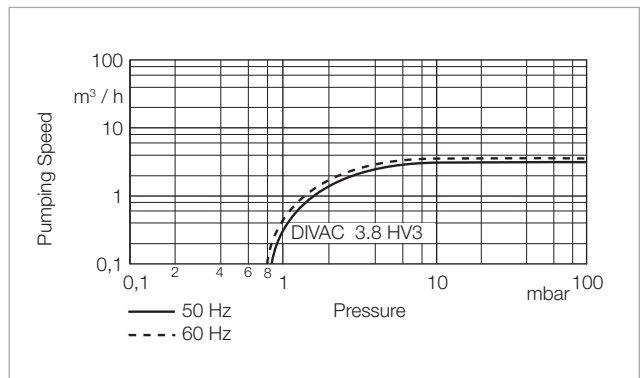

Pumping speed curve of the DIVAC 3.8 HV3

Technical Data
DIVAC

		1.4 HV3	3.8 HV3
Max. pumping speed			
50 Hz	m ³ /h (cfm)	1.3 (0.77)	3.4 (2.00)
60 Hz	m ³ /h (cfm)	-	3.8 (2.24)
Ultimate pressure	mbar (Torr)	≤ 1.5 (≤ 1.13)	≤ 1.0 (≤ 0.75)
Max. exhaust back pressure (absolute)	mbar (Torr)	1500 (1125)	1500 (1125)
Pump heads		3	3
Connection			
Inlet (suction side)		Hose nozzle ID 9	Hose nozzle ID 10
Exhaust (delivery side)		Hose nozzle ID 9	Hose nozzle ID 10
Thread (suction and delivery side)		G 1/8"	G 1/4"
Noise level acc. to DIN 45 635 Part 13, approx.	dB(A)	48	54
Permissible gas admission temperature, max.	°C (°F)	+5 to +40 (+41 to +104)	+5 to +40 (+41 to +104)
Permissible ambient temperature, max.	°C (°F)	+5 to +40 (+41 to +104)	+5 to +40 (+41 to +104)
Voltage / nominal frequency (1-ph. motor)			
Schuko plug	V / Hz	90-230 / 50-60	90-230 / 50-60
NEMA plug	V / Hz	-	115 / 50-60
Protective class	IP	20	20
Motor power	W	120	250
at ultimate pressure	W	35	190
Current consumption	A	1.3	1.7
Nominal speed, approx. (50/60 Hz)	min ⁻¹	1500	1500/1800
Dimensions (W x H x D), approx.	mm (in.)	324 x 158 x 226 (12.76 x 6.22 x 8.90)	295 x 240 x 203 (11.61 x 9.45 x 7.99)
Weight, approx.	kg (lbs)	10.5 (23.18)	18.9 (41.72)
Material			
Pump head		Aluminum	Aluminum
Structured diaphragm		EPDM	EPDM
Valves		EPDM	EPDM
Nozzles		PA	PA

Ordering Information
DIVAC

	1.4 HV3	3.8 HV3
	Part No.	Part No.
Diaphragm vacuum backing pumps for turbomolecular pumps including 1 m (3.5 ft) long mains cord, country-specific plug, silencer, rubber feet, as well as ON/OFF switch		
90-230 V / 50-60 Hz	127 90 V	-
230 V / 50-60 Hz	-	127 95 V
115 V / 50-60 Hz	-	127 96 V
Exhaust silencer		
1.4 with connection G 1/8"	127 90 A	-
3.8 with connection G 1/4"	-	127 95 A
Spare parts kit	EK057456	EK12768

DIVAC 4.8 VT

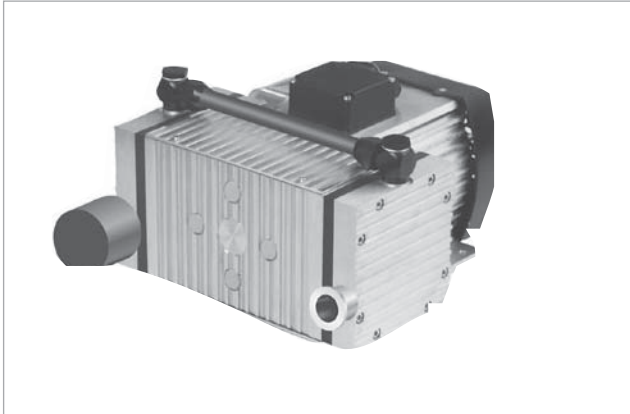

DIVAC 4.8 VT

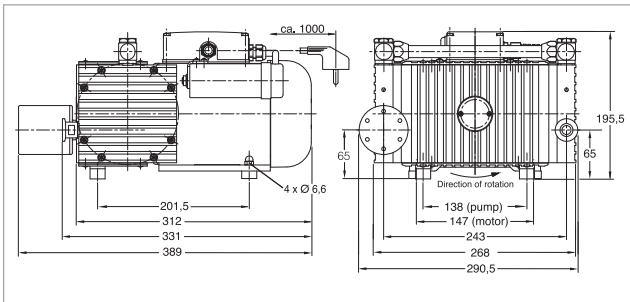

Dimensional drawing for the DIVAC 4.8 VT

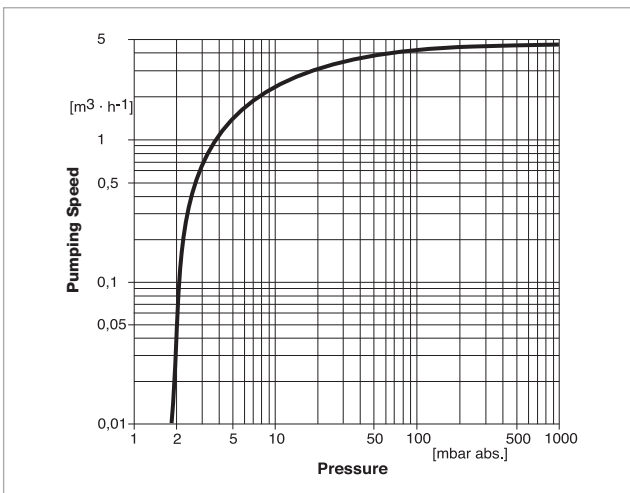

Pumping speed curve of the DIVAC 4.8 VT

Technical Data
DIVAC 4.8 VT

Max. pumping speed (atm.)	m ³ /h (cfm)	4.8 (2.83)
Ultimate pressure (absolute)	mbar (Torr)	≤ 2 (≤ 1.5)
Max. exhaust back pressure (absolute)	mbar (Torr)	2000 (1500)
Pump heads		2
Connection		
Inlet (suction side)	DN	16 KF
Exhaust (delivery side)	DN	Silencer
Thread (suction and delivery side)	G	G 3/8"
Noise level acc. to DIN 45 635 Part 13, approx.	dB(A)	55
Permissible gas admission temperature, max.	°C (°F)	+5 to +40 (+41 to +104)
Permissible ambient temperature, max.	°C (°F)	+5 to +40 (+41 to +104)
Voltage / nominal frequency (1-ph. motor)		
Schuko plug	V / Hz	230 / 50 ± 10%
NEMA plug	V / Hz	115 / 60 ± 10%
Protective class	IP	54
Motor power	W	350
Current consumption	A	2.6
Nominal speed, approx. (50 Hz)	min ⁻¹	1500
Dimensions (W x H x D), approx.	mm (in.)	324 x 273 x 220 (12.76 x 10.75 x 8.66)
Weight, approx.	kg (lbs)	18.0 (39.74)
Material		
Diaphragm		EPDM
Valves		Viton
Pump head		Aluminum

Ordering Information
DIVAC 4.8 VT

	Part No.
Diaphragm vacuum backing pumps for turbomolecular pumps including 1 m (3.5 ft) long mains cord, country-specific plug, silencer, rubber feet, as well as ON/OFF switch 230 V / 50 Hz ± 10%	127 92
Spare parts kit consisting of 2 diaphragms, 4 valves, 4 valve gaskets, 4 piping gaskets	EK 127 97
Exhaust silencer	127 94

T = For use in connection with Turbomolecular pumps

L = Very low ultimate pressure (Low pressure)

V = Low vibration levels (Low Vibration)

General

Applications and Accessories for SCROLLVAC Pumps

Pumps	SC 5 D	SC 15 D	SC 30 D	SC 60 D
Applications				
Electron beam melting	■	■	■	■
Lasers	■	■	■	■
Leak detection systems	■		■	
Accelerators / Synchrotrons	■	■	■	■
Surface analysis instruments	■			
Scanning electron microscopy	■	■	■	■
Loadlock		■	■	■
Spectroscopy	■			
Lamps manufacture	■	■	■	■
As backing pump for turbomolecular pump systems	■	■	■	■

Products

Oil-free Scroll Vacuum Pumps SCROLLVAC SC 5 to SC 60 D



Scroll vacuum pump SCROLLVAC, from left to right: SC 60 D, SC 30 D, SC 15 D, SC 5 D

Advantage for the User

- Absolutely oil-free
- High effective pumping speed
- Low ultimate pressure
- Low noise level
- Low vibration operation
- Atmospheric inlet pressure allowable
- Low weight
- Air cooling
- Low power consumption
- Integrated operating hours counter

Typical Applications

- Electron beam welding
- Lasers
- Leak detection systems
- Accelerators / synchrotrons
- Surface analysis instruments
- Scanning electron microscopes
- Load lock
- Spectroscopy
- Lamp manufacturing
- As a backing pump for turbomolecular pump systems

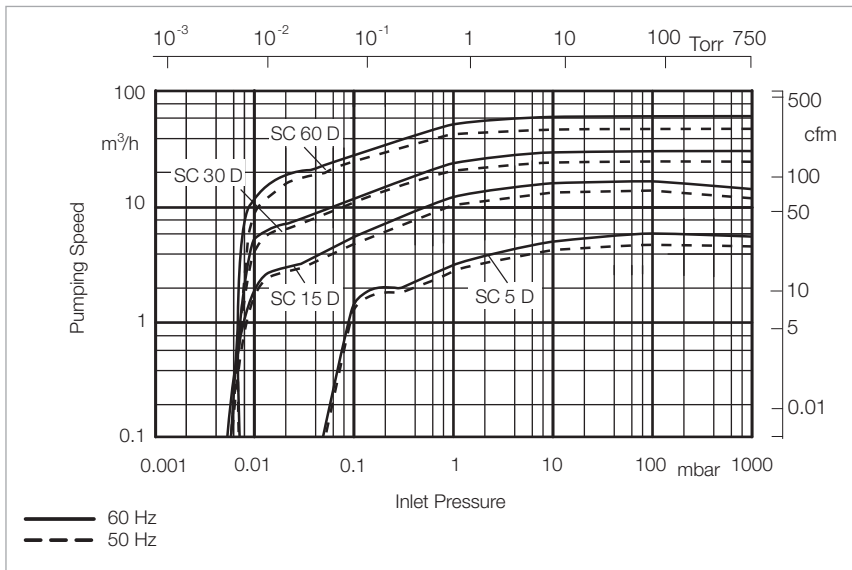

Pumping speed curves for the scroll vacuum pumps SCROLLVAC SC - D

In 1905 the principle of the scroll compressor was developed by the Frenchman Leon Creux. The scroll pump is now being used as an oil-free vacuum pump. Every scroll pump consists of two Archimedes spirals engaging each other with an offset of 180°. Thus several crescent-shaped pockets of differing sizes are created. By means of an eccentric drive, a second spiral is made to orbit about a fixed spiral, thus reducing the volume of the pockets and compressing gases from the outside towards the inside thereby pumping the gases. Important to the quality of a scroll pump is that precise manufacturing tolerances are maintained and that suitable materials are selected.

Maintenance Intervals

In order to maintain the performance of the pump, a standard maintenance is required after a certain number of operating hours.

For this we are offering complete maintenance kits

- Small maintenance kit (Minor Kit) after 8,000 h or at latest after an operating time of 12 months
- Large maintenance kit (Major Kit) after 16,000 hours or at latest after an operating time of 24 months

Warranty

Upon signing a warranty contract, we will grant a two-year warranty for faulty material when complying with the required maintenance intervals.

Excluded are wearing parts as well as well wear due to the process.

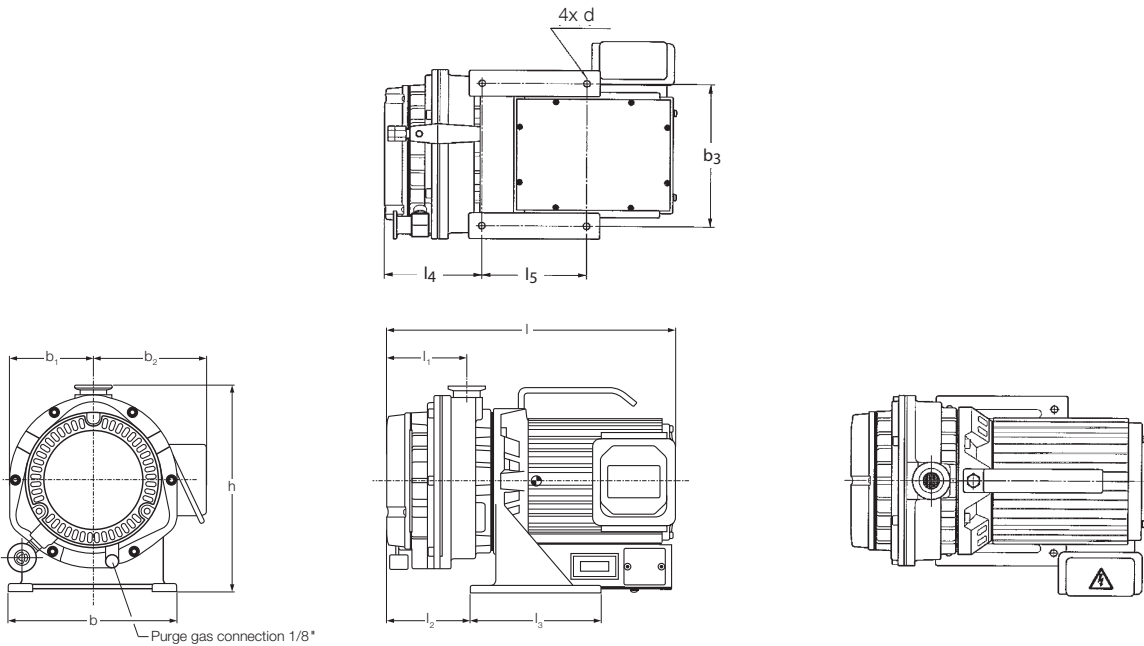

Type		b	b ₁	b ₂	b ₃	∅ d	h	h ₁	h ₂	l	l ₁	l ₂	l ₃	l ₄	l ₅	l ₆	l ₇
SC 5 D	mm	180	91	123	154	7	225	–	–	308	85	90	140	104	112	–	–
	in.	7.09	3.58	4.84	6.06	0.28	8.86	–	–	12.13	3.35	3.54	5.51	40.95	4.41	–	–
SC 15 D	mm	180	222	–	136	11	336	38	73.5	400 ¹⁾	96	101	170	121	130	52	40
	in.	7.09	8.74	–	5.35	0.43	13.23	1.50	2.89	15.75 ¹⁾	3.78	3.98	6.69	4.76	5.12	2.05	1.58

¹⁾ 370 (14.57 in.) for 3~ version

3 phase

1 phase

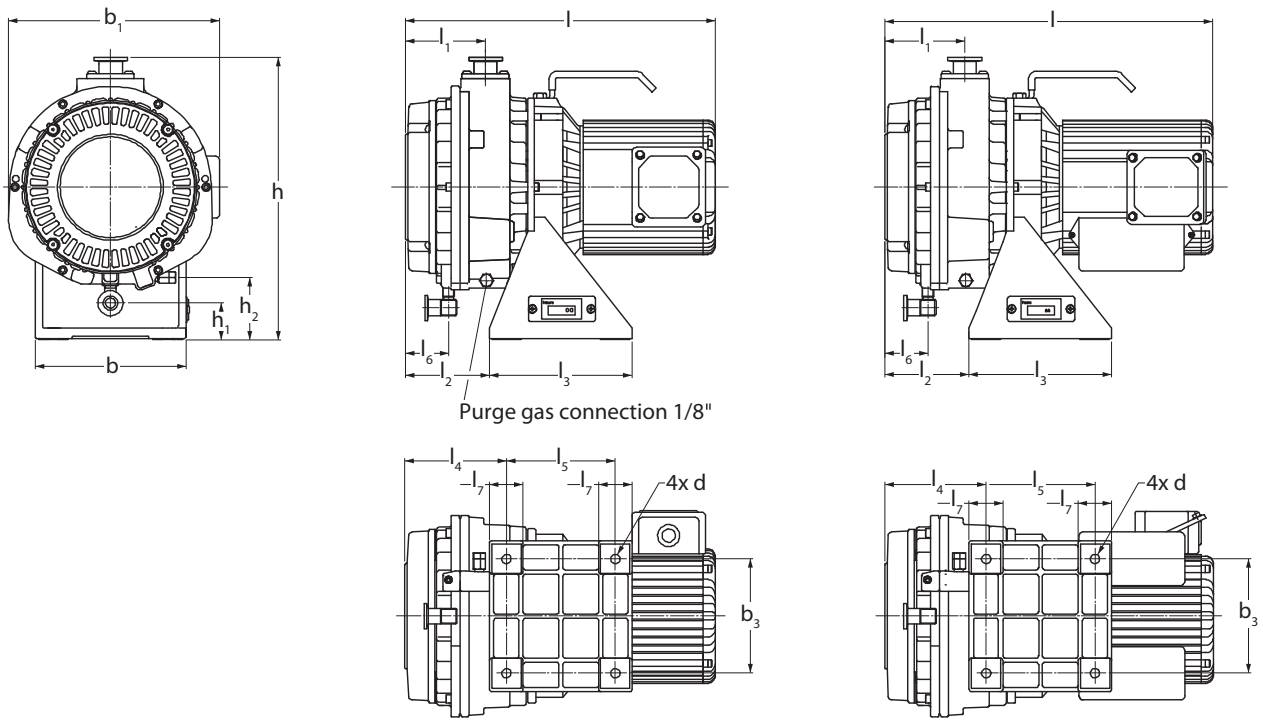

Dimensional drawing for the scroll vacuum pump SCROLLVAC SC 5 D (above) and SC 15 D (below)

3 phase

1 phase

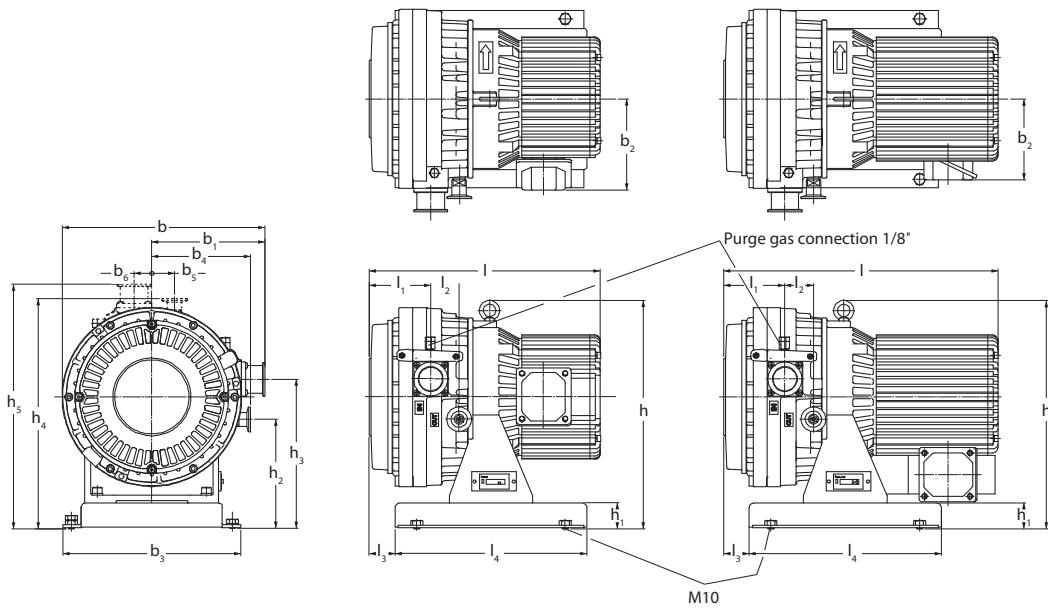

Type		b	b ₁	b ₂	b ₃	b ₄	b ₅	b ₆	h	h ₁	h ₂	h ₃	h ₄	h ₅	l	l ₁	l ₂	l ₃	l ₄
SC 30 D	mm	328	183	131 ¹⁾	288	159	36	29	372	42	178	243	373	397	443 ²⁾	99	46	42	310
	in.	12.91	7.20	5.16 ¹⁾	11.34	6.26	1.42	1.14	4.65	1.65	7.01	9.57	14.69	15.63	17.44 ²⁾	3.90	1.81	1.65	12.20
SC 60 D	mm	390	218	168	320	-	-	-	421	42	163	285	-	-	467	133	-	55	350
	in.	13.35	8.58	6.61	12.60	-	-	-	16.58	1.65	6.42	11.22	-	-	18.39	5.24	-	2.17	13.78

¹⁾ 147 (5.79 in.) for 3~ version

²⁾ 372 (14.65 in.) for 3~ version

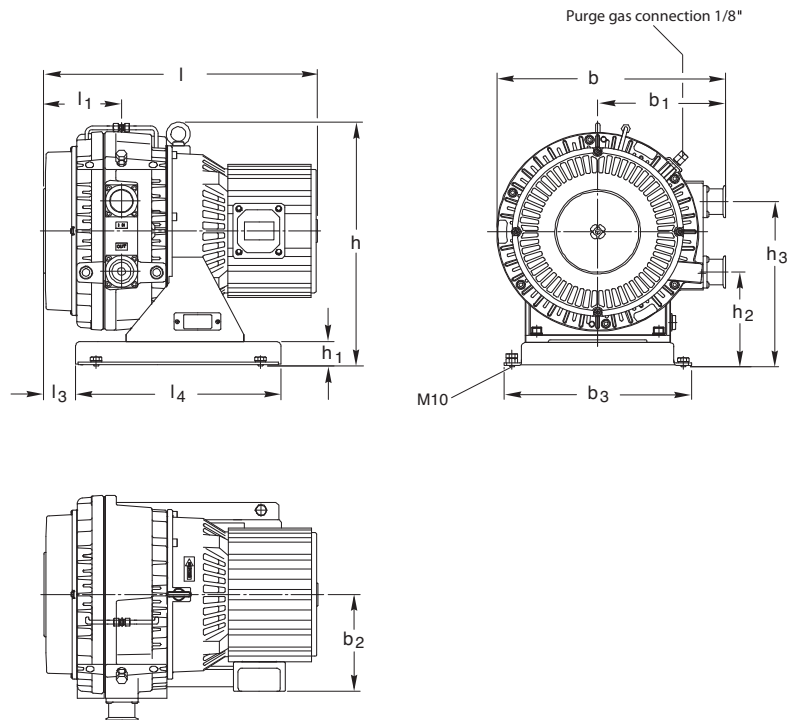

Dimensional drawing for the scroll vacuum pump SCROLLVAC SC 30 D (above) and SC 60 D (below)

Technical Data

SCROLLVAC

		SC 5 D	SC 15 D	SC 30 D	SC 60 D
Nominal pumping speed ¹⁾					
50 Hz	m ³ /h (cfm)	5.4 (3.2)	15.0 (8.8)	30.0 (17.7)	60.0 (35.4)
60 Hz	m ³ /h (cfm)	6.4 (3.8)	18.0 (10.6)	36.0 (21.2)	72.0 (42.4)
Pumping speed ¹⁾					
50 Hz	m ³ /h (cfm)	4.8 (2.8)	13.0 (7.7)	26.0 (13.3)	52.0 (30.6)
60 Hz	m ³ /h (cfm)	6.0 (3.5)	15.5 (9.1)	31.0 (18.3)	62.0 (36.5)
Attainable ultimate pressure	mbar (Torr)	≤ 0.05 (≤ 0.038)	≤ 0.016 (≤ 0.012)	≤ 0.01 (≤ 0.008)	≤ 0.01 (≤ 0.008)
Leak rate	mbar l/s	1 x 10 ⁻⁶	1 x 10 ⁻⁶	1 x 10 ⁻⁶	1 x 10 ⁻⁴
Maximum inlet pressure		Atmosphere	Atmosphere	Atmosphere	Atmosphere
Permissible ambient temperature		°C (°F)	°C (°F)	°C (°F)	°C (°F)
		+5 to +40 (+41 to +104)	+5 to +40 (+41 to +104)	+5 to +40 (+41 to +104)	+5 to +40 (+41 to +104)
Connections					
Inlet	DN	25	25	40	40
Exhaust	DN	16	16	25	40
Cooling		Air	Air	Air	Air
Water vapor capacity with purge, max.		g/h l/min	g/h l/min	g/h l/min	g/h l/min
		0.2 9	1.04 10	1.04 10	1.04 10
Protection class		IP	IP	IP	IP
		20	20	20	20
Motor power		W (hp)	W (hp)	W (hp)	W (hp)
		150 (0.20)	400 (0.54)	600 (0.82)	1400 (1.90)
Motor speed		min ⁻¹ (rpm)	min ⁻¹ (rpm)	min ⁻¹ (rpm)	min ⁻¹ (rpm)
50 Hz		1440 (1440)	1450 (1450)	1450 (1450)	1460 (1460)
60 Hz		1740 (1740)	1730 (1730)	1730 (1730)	1760 (1760)
Motor voltage		1-ph. ²⁾	1-ph. ²⁾	1-ph. ²⁾	1-ph. ²⁾
		100 V / 50 Hz 100 - 115 V / 60 Hz 200 - 230 V / 50/60 Hz	100 V / 50 Hz 100 - 115 V / 60 Hz 200 - 230 V / 50/60 Hz	100 V / 50 Hz 100 - 115 V / 60 Hz 200 - 230 V / 50/60 Hz	100 V / 50 Hz 100 - 115 V / 60 Hz 200 - 230 V / 50/60 Hz
		3-ph.	3-ph.	3-ph.	3-ph.
			200 V, 380 - 415 V / 50 Hz 200 - 380 V, 460 V / 60 Hz	200 V, 380 - 415 V / 50 Hz 200 - 380 V, 460 V / 60 Hz	200 V, 380 - 400 - 415 V / 50 Hz 200 - 220 - 230 V, 460 V, 60 Hz
Noise level at 1 m (3.5 ft), free field measurement		dB(A)	dB(A)	dB(A)	dB(A)
		≤ 52	≤ 58	≤ 62	≤ 67
Dimensions (W x H x D)		mm (in.)	mm (in.)	mm (in.)	mm (in.)
		308 x 214 x 225 (12.13 x 8.43 x 8.86)	400 x 252 x 336 (15.75 x 9.92 x 13.23)	443 x 328 x 372 (17.44 x 12.91 x 14.65)	467 x 390 x 421 (18.39 x 15.35 x 16.57)
Weight		kg (lbs)	kg (lbs)	kg (lbs)	kg (lbs)
Single-phase motor		14 (30.9)	25 (55.2)	44 (97.1)	-
Three-phase motor		-	23 (50.8)	38 (83.9)	60 (132.5)

¹⁾ In accordance with DIN 28 400

²⁾ The Part No. for single-phase pumps will determine the voltage range at delivery

Ordering Information

SCROLLVAC

	SC 5 D	SC 15 D	SC 30 D	SC 60 D
	Part No.	Part No.	Part No.	Part No.
Oil-free scroll vacuum pump				
Single-phase motor, with cable and plug				
Europe (Schuko plug, 230 V)	133 000	133 001	133 002	-
US / Japan (NEMA plug, 115 V)	133 100	133 101	133 102	-
Three-phase motor, without cable	-	133 003	133 004	133 008
Maintenance kits				
Small maintenance kit (after 8,000 h)				
Minor Kit	EK 870000496	EK 870000497	EK 870000498	EK 870000519
Large maintenance kit (after 16,000 h)				
Major Kit	EK 870000499	EK 870000500	EK 870000501	EK 870000520
Tool kit SC 5/15/30/60 D	EK 870000502	EK 870000503	EK 870000503	EK 870000521
Scroll profile gasket (Tip Seal)	E 870000510	E 870000511	E 870000512	E 870000522
Shaft installation kit (Pin Crank Kit)	EK 870000507	EK 870000508	EK 870000509	EK 870000523

General

Applications for LEYVAC Pumps

	LEYVAC LV 80	LEYVAC LV 80 C	LEYVAC LV 140	LEYVAC LV 140 C
Applications				
Process industry				
Industrial furnaces	■	■	■	■
Degassing	■	■	■	■
Charging	■	■	■	■
Casting	■	■	■	■
Drying processes in general			■	■
Freeze drying	■	■	■	■
Packaging	■	■	■	■
Coating				
CVD coating	■	■	■	■
Plasma coating	■	■	■	■
Glass coating	■	■	■	■
Web coating	■	■	■	■
Solar				
CVD/PECVD	■	■	■	■
Crystal pulling and casting	■	■	■	■
Support functions				
Regeneration of cryo pumps	■	■	■	■
Forevacuum pumps for Turbomolecular pumps	■	■	■	■

Dry compressing
vacuum pumps

Dry Compressing
Vacuum Pumps

General

LEYVAC

Excellent efficiency in every respect

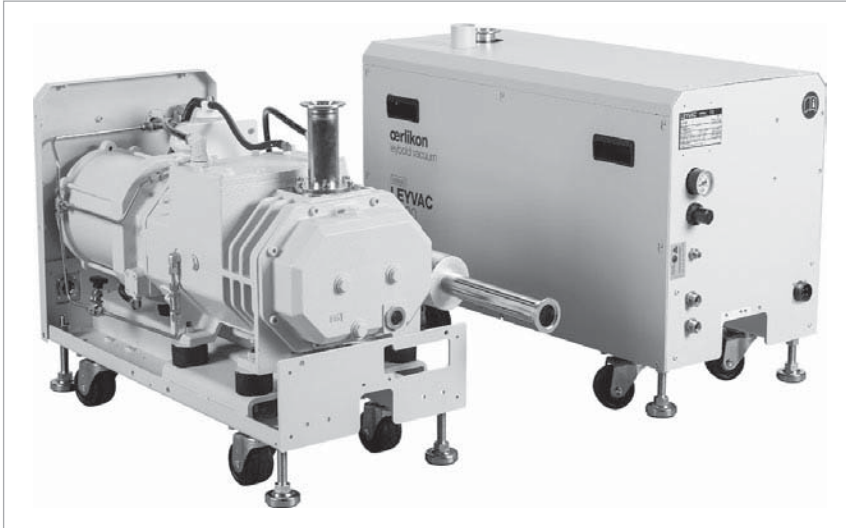

LEYVAC LV 80 and 140 (left), as well LEYVAC LV 80 C and 140 C (right)

Our LEYVAC dry vacuum pumps provide power combined with high performance.

This product range for the 100 m³/h market has been designed to meet the special needs of industrial processes and coating applications.

LEYVAC pumps and system combinations are rugged, reliable and durable, ready to cope with harsh processes.

The LEYVAC product line comprises the models LEYVAC LV 80, LV 80 C, LV 140 and LV 140 C

Advantages to the User

- Dry pump technology
- Shortest pumpdown times through high pumping speed for air already starting at atmospheric pressure
- High pumping speed for air and H₂
- Hermetically tight
 - No shaft seals
 - No oil leakage
 - Safe pumping of toxic gases
- High reliability
 - Long service intervals (up to 5 years)
 - High uptime
 - Robust and durable design
- One motor solution
 - Multi-voltage, dual frequency motor operable at 200 V - 460 V and 50/60 Hz
- Easy and modular
 - Direct coupling of roots booster pumps without frames for models RUVAC WS/WSU 251/501 and WH 700 provides enhanced pumping performance

Typical Application

- Process industry
 - Industrial furnaces
 - Degassing
 - Charging
 - Casting
 - Drying processes in general
 - Freeze drying
 - Packaging
- Coating
 - CVD coating
 - Plasma coating
 - Glass coating
 - Web coating
- Solar
 - CVD/PECVD
 - Crystal pulling and casting
- Support functions
 - Regeneration of cryo pumps
 - Forevacuum pumps for turbomolecular pumps

Performance Details at a Glance

LEYVAC dry vacuum pumps provide **optimized**

- System uptime
 - Robust design based on the proven RUVAC and DRYVAC technology
 - Most effective cooling system
 - Thermal switch protection
 - Tolerant to pressure shocks
 - Long intervals for bearing exchange
- Process safety
 - designed for harsh applications
- High pumping speed already at high intake pressures
- Good pumping speed also for lighter gases (with purge)
- Low noise and low heat emission
- Price-to-performance ratio
 - Low investment costs
 - Small, price optimized pumping systems

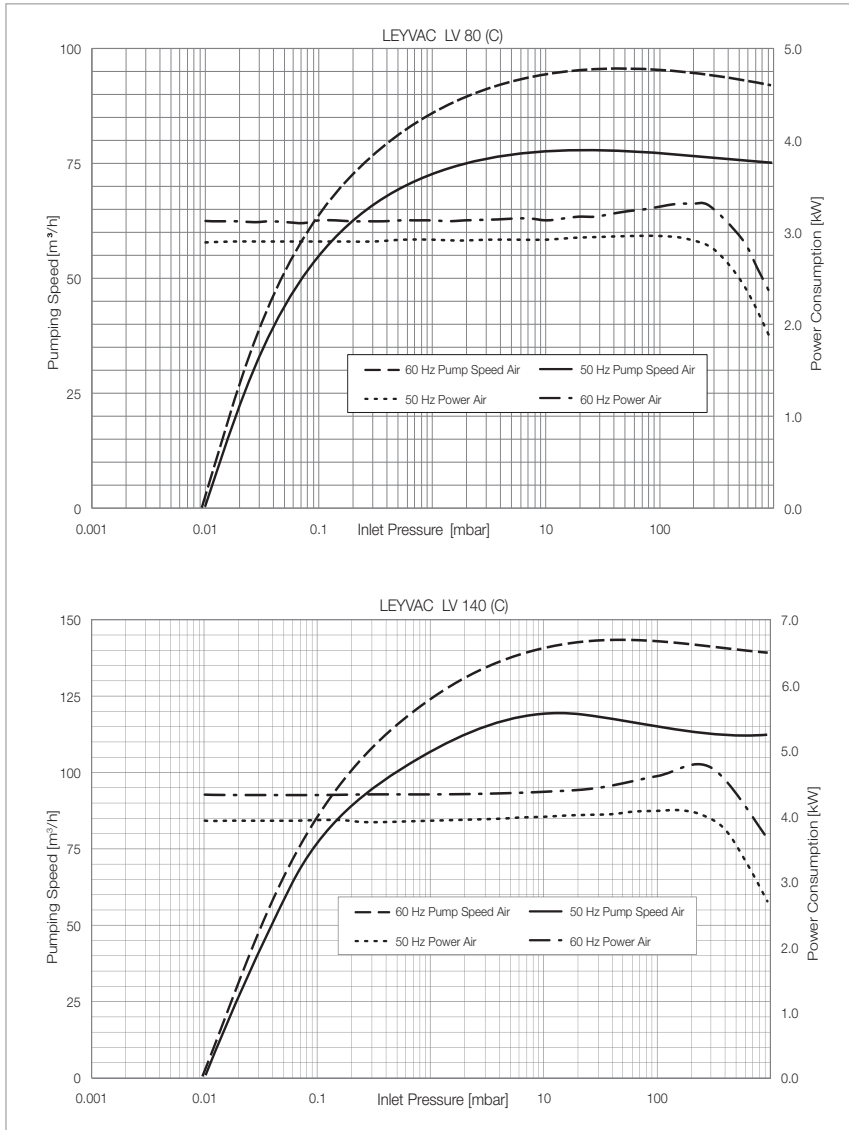

Pumping speed curves of the LEYVAC LV 80/C and LEYVAC LV 140/C

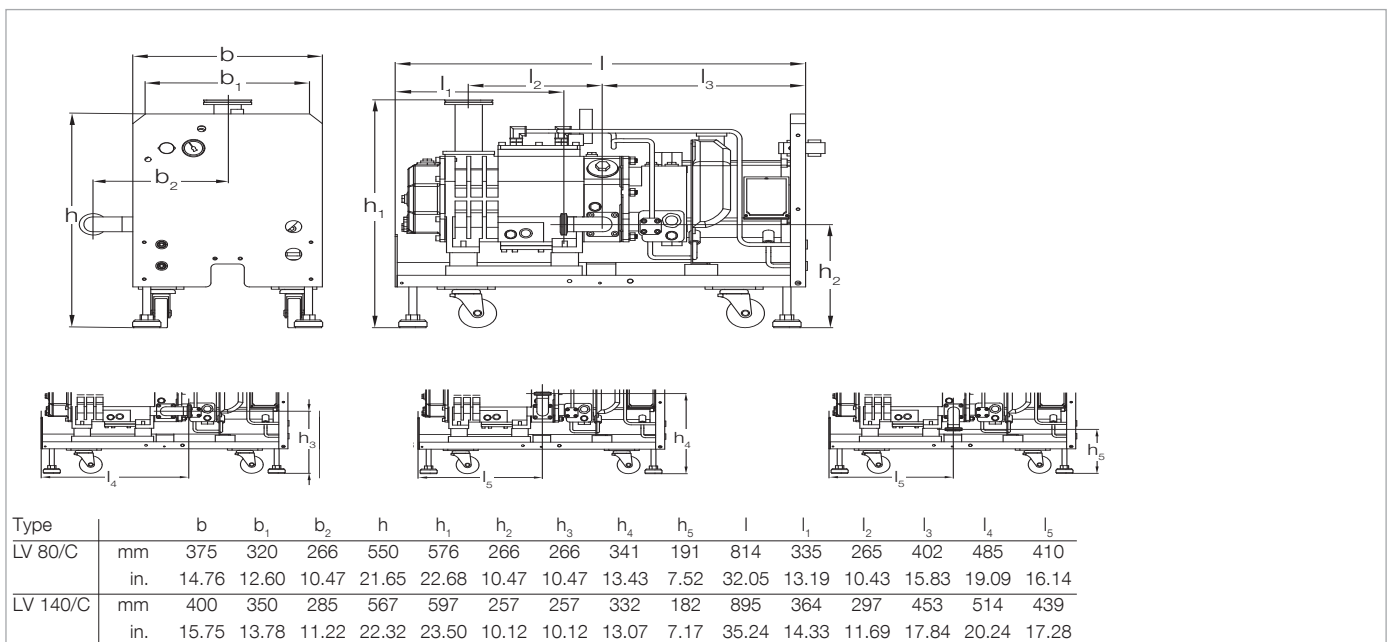

Dimensional drawing for the LEYVAC LV 80/C and LV 140/C; below for exhaust connection

Products

Technical Data

LEYVAC

with Housing

		LV 80	LV 140	LV 80 C	LV 140 C
Nominal pumping speed without gas ballast at 50/60 Hz	m ³ x h ⁻¹ (cfm)	80/96 (47.1/56.5)	125/145 (73.6/85.3)	80/96 (47.1/56.5)	125/145 (73.6/85.3)
Ultimate pressure with seal and rotor purge	mbar (Torr)	1 x 10 ⁻² (0.75 x 10 ⁻²) ¹⁾	1 x 10 ⁻² (0.75 x 10 ⁻²) ¹⁾	1 x 10 ⁻² (0.75 x 10 ⁻²) ¹⁾	1 x 10 ⁻² (0.75 x 10 ⁻²) ¹⁾
Power consumption at ultimate pressure and 50/60 Hz operation	kW (hp)	2.9/3.2 (3.9/4.3)	3.9/4.3 (5.2/5.8)	2.9/3.2 (3.9/4.3)	3.9/4.3 (5.2/5.8)
Weight, approx.	kg (lbs)	280 (617)	300 (661)	285 (628)	305 (672)
Noise level ¹⁾	dB(A)	< 65	< 65	< 65	< 65
Connection flange					
Intake	DN	63 ISO-K	63 ISO-K	63 ISO-K	63 ISO-K
Discharge	DN	40 ISO-KF	40 ISO-KF	40 ISO-KF	40 ISO-KF
Mains voltage (± 10%)	V	200 - 460	200 - 460	200 - 460	200 - 460
Nominal power at 50/60 Hz	kW (hp)	3.75 (5.0)	5.5 (7.4)	3.75 (5.0)	5.5 (7.4)
Nominal current consumption 50/60 Hz at 400 V	A	6	8	6	8
Cooling		water	water	water	water
Cooling water temperature	°C (°F)	+5 to +35 (+41 to +95)	+5 to +35 (+41 to +95)	+5 to +35 (+41 to +95)	+5 to +35 (+41 to +95)
Min. cooling water throughput	l/min	3	3	3	3
Water vapor tolerance (with gas ballast) 80 slm 50/60 Hz	mbar (Torr)	20/30 (15.0/22.5)	125/160 (93.8/120.0)	20/30 (15.0/22.5)	125/160 (93.8/120.0)
Water vapor capacity (with gas ballast) 80 slm 50/60 Hz	kg/h	1.24/2.3	11.5/18.0	1.24/2.3	11.5/18.0
Permissible ambient temperature	°C (°F)	+5 to +45 (+41 to +113)	+5 to +45 (+41 to +113)	+5 to +45 (+41 to +113)	+5 to +45 (+41 to +113)
Protection class EN 60529	IP	54	54	54	54
Dimensions (W x H x D)	mm (in.)	814 x 375 x 550 (32.05 x 14.76 x 21.65)	895 x 400 x 567 (35.24 x 15.75 x 22.32)	814 x 375 x 550 (32.05 x 14.76 x 21.65)	895 x 400 x 567 (35.24 x 15.75 x 22.32)

¹⁾ At ultimate pressure and with rigid exhaust line DIN EN ISO 2151

Ordering Information

LEYVAC

with Housing

	LV 80	LV 140	LV 80 C	LV 140 C
	Part No.	Part No.	Part No.	Part No.
Dry compressing vacuum pump LEYVAC including LEYBONOL LVO 410 lubricant, base plate, castors, temperature switch, shaft seal and rotor purge additionally with casing	115080V15 —	115140V15 —	— 115080V30	— 115140V30
Accessories				
Non-return ball valve	115005A01	115005A01	115005A01	115005A01
Non-return valve, spring-loaded	115005A02	115005A02	115005A02	115005A02
Roots pump adapter for RUVAC WS/WSU 251/501 and RUVAC WH 700	115005A03	115005A03	115005A03	115005A03
Exhaust pressure sensor LV 80 LV 140	115005A10 115005A11	115005A10 115005A11	115005A10 115005A11	115005A10 115005A11
Gas ballast kit manually operated 24 V	115005A12 115005A13	115005A12 115005A13	115005A12 115005A13	115005A12 115005A13
Silencer standard (with integrated non-return valve) serviceable emptyable	115005A20 115005A22 115005A23	115005A20 115005A22 115005A23	115005A20 115005A22 115005A23	115005A20 115005A22 115005A23
High-performance silencer	115005A21	115005A21	115005A21	115005A21
Elbow for silencer, emptyable	115005A26	115005A26	115005A26	115005A26
Inlet screen	115005A28	115005A28	115005A28	115005A28
External frequency converter (including mains filter) for LEYVAC LV 80 (400 V) LEYVAC LV 140 (400 V)	115005A30 115005A35	115005A30 115005A35	115005A30 115005A35	115005A30 115005A35
Profibus module ¹⁾	155212V	155212V	155212V	155212V
Relais module (digital output) ¹⁾	112005A01	112005A01	112005A01	112005A01
Ethernet interface module ¹⁾	112005A02	112005A02	112005A02	112005A02
ProfiNet module ¹⁾	112005A35	112005A35	112005A35	112005A35
EtherCAT module ¹⁾	112005A36	112005A36	112005A36	112005A36

¹⁾ For optional, external frequency converter

General

Applications for SCREWLINE Pumps

Dry Compressing Scroll Vacuum Pumps	SCREWLINE SP 250 (ATEX)	SCREWLINE 630 (F) ATEX
Application		
Laser engineering	■	■
Vacuum coating	■	■
Lamination	■	■
Loadlock chambers	■	■
Mechanical engineering	■	■
Automotive industry	■	■
Metallurgy/Furnaces	■	■
Crystal pulling	■	■
Degassing	■	■
Electrical engineering	■	■
Energy technology	■	■
Welding technology	■	■
Lamps/Tubes manufacture	■	■
Cooling and air conditioning	■	■
Chemistry/Pharmaceuticals	■	■
Chemical research laboratories	■	■
Vacuum drying	■	■
Freeze drying systems	■	■
Environmental engineering	■	■
Packaging	■	■
Medical technology	■	■
Analytical engineering	■	■
Research and development	■	■
Space simulation	■	■
Backing pump for HV-Systems	■	■

Dry Compressing
Vacuum Pumps

General



Pump system Screw Vacuum Pump SCREWLINE SP 630 with RUVAC WAU 2001

The Screw Vacuum Pumps SCREWLINE were developed in view of the special requirements of industrial applications. The innovative design allows these pumps to be used whenever reliable, compact and low maintenance vacuum solutions are required.

Principle of Operation

Screw Vacuum Pumps are dry compressing backing pumps, the operation of which is based on the screw principle. The pumping chamber of the pump is formed by two synchronised positive displacement rotors and the housing enclosing these. Since the rotors rotate in opposite directions, the chambers move steadily from the intake to the exhaust side of the pumps thereby resulting in a smooth pumping action (see figure below). Since with a single Screw Vacuum Pump rotor pair a multistage compression process is implemented, the component count in the pumping path is very low. In this way maintenance and servicing work is much simplified.

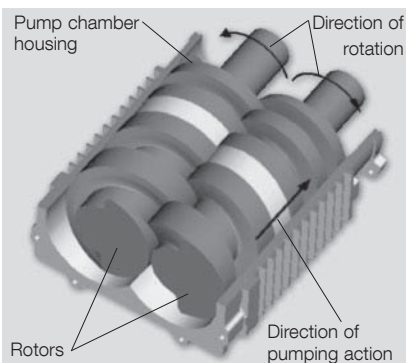

Principle of operation of the SCREWLINE Line

Properties

The direct pumping path without multiple deflections for the medium make the Screw Vacuum Pumps highly insensitive to foreign materials. This ensures a high uptime in industrial processes.

The two non-contacting shaft-seals are practically wear-free, which allows for very long maintenance intervals. For standard applications no purge gas is required. However, a purge gas supply can be connected as an option to purge the seals, should the application process require this.

Because of the cantilevered bearing arrangement for the Screw Vacuum Pump rotors, a potential source of failure (i.e. a bearing on the intake side) is entirely eliminated. On the one hand, no lubricants from the bearings can enter into the vacuum process, and the other hand also an impairment of the bearing by aggressive process media can be excluded.

A further benefit of the cantilevered bearing arrangement is the easy

accessibility of the pump chamber. This innovative design feature allows the removal of the pump housing without time-consuming and costly disassembly of the bearings. Thus on-site cleaning of all surfaces in contact with the medium is possible. In particular, if the processes involved considerable amounts of contaminants this is a significant advantage which ensures a long uptime.

The low exhaust temperature is an important advantage of the Screw Vacuum Pumps. Owing to the design of the screw rotors, a temperature of maximum 100 °C (212 °F) is attained inside the pump. Thus deposits of many substances are avoided which react at high temperatures. This makes the pump unique and many customers, above all from the field of coating, value this highly.

Should deposits form in spite of this, then the easy to disassemble housing facilitates rapid cleaning.

Besides the integrated oil cooling arrangement for the rotors, the Screw Vacuum Pumps are air-cooled from the outside. Here rotor and housings are thermally linked via the oil cooler. Thus, Screw Vacuum Pumps adapt themselves ideally to the ambient conditions under changing operating situations.



Oil/water cooling unit SP 630 F

A water-cooled version is offered as Screw Vacuum Pumps SP 630 F. This product version is intended for operation in air-conditioned rooms.

The Screw Pumps portfolio is completed through ATEX-certified variants.

Moreover, the Screw Vacuum Pumps portfolio also includes pump versions suited for pumping pure oxygen (O₂).

Maintenance and Monitoring

During the development of the Screw Vacuum Pumps, special emphasis was placed on a particularly simple maintenance concept. This has been implemented through the cantilevered bearing arrangement, with all maintenance components and controls having been located on the so-called service side for easy accessibility. Thus, the space requirement which needs to be taken into account during planning has been optimized. The lower space requirement gives the user more flexibility during installation of the pump.

The monitoring system SP-GUARD was developed especially for constant real-time monitoring of the operational status of the Screw Vacuum Pumps. The operating parameters are con-

stantly acquired and processed. This enables the user to introduce preventive actions early enough so as to ensure trouble-free operation of his Screw Vacuum Pumps. The key current operating parameters can be read off from a local display. Moreover, connection to a PLC and remote monitoring is possible. Maintenance of the Screw Vacuum Pumps will generally be limited to a regular visual inspection of the pump and the annual change of gear oil and oil filter. The oil fill ports as well as the filters are readily accessible and can be easily exchanged.

With the aid of a flushing kit (optional) it is possible to clean the pump chamber, while the pump is operating without process. Deposits due to the process can thus be removed effectively and quickly without the need of having to disassemble the housing.

Also, cleaning of the air/oil heat exchanger can be done simply on-site by blowing out the heat exchanger with compressed air.

Accessories

Screw Vacuum Pumps offer to the user a high degree of flexibility. Inlet and exhaust connections are made through universal flanges, respectively clamped flanges, permit simple integration within the system. Through the accessories which are available, the pump can be optimally adapted to the individual requirements of differing applications.

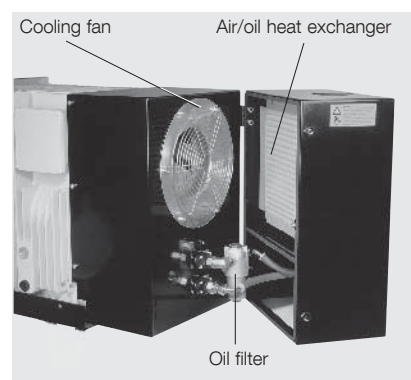

Oil/water cooling unit SP 630

Advantages to the User

- Utmost reliability
- Protection of the pump through monitoring vital parameters by means of the SP-GUARD
- Minimum downtimes owing to rapid cleaning of the pump chamber (in less than one hour)
- Avoidance of deposits through low internal temperatures
- Minimum operating costs
- The only directly air cooled screw vacuum pump on the market. No need for cooling water
- No seal gas needed for standard applications
- No oil in the pump chamber. Thus no need for disposing of contaminated oil
- Gear oil change only every two years
- Utmost flexibility
- Direct adaptation of RUVAC pumps for increased pumping speed up to approximately 7000 m³/h
- Multi-flange for all commonly used pipe connections
- Flushing kit for constant cleaning of the pump chamber
- Silencing hoods for a further reduction of noise emissions

Typical Applications

- Industrial furnaces
- Coating technology
- Load lock chambers
- Metallurgical systems
- Packaging technology
- Drying processes
- Degassing
- Research and development
- Lamps and tubes manufacture
- Automotive industry
- Packaging industry
- Space simulation
- Electrical engineering
- Energy research

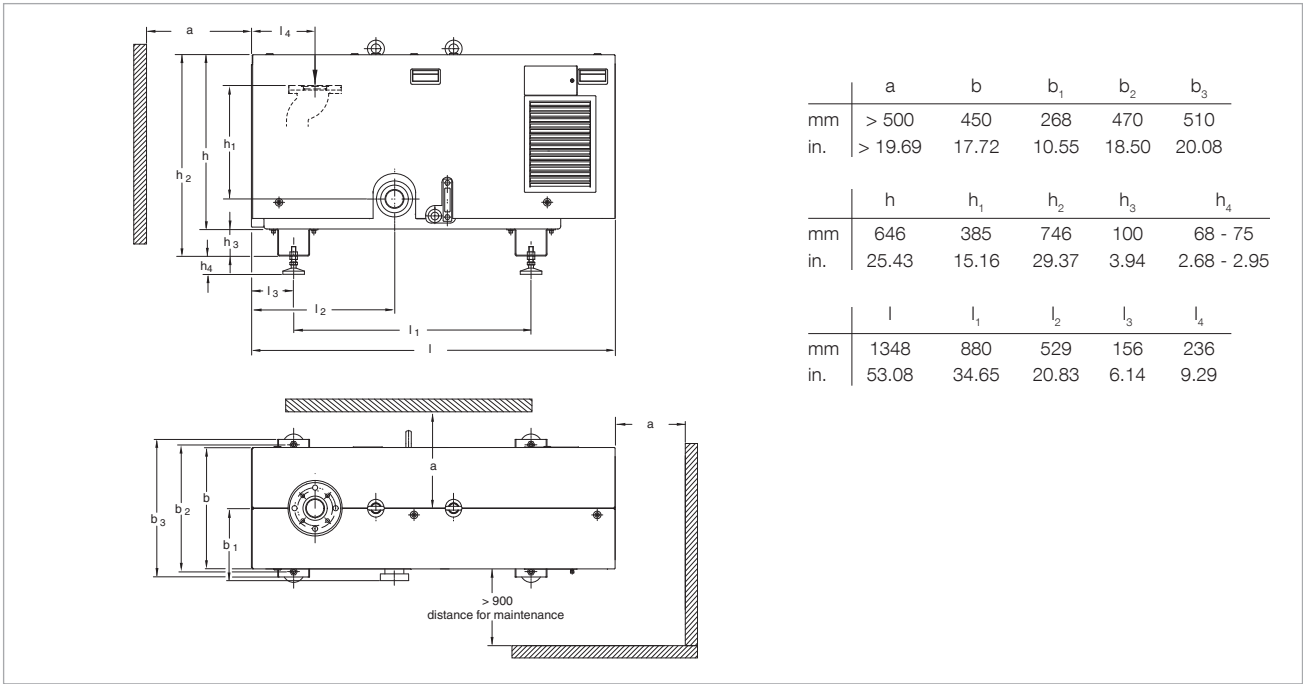

Dimensional drawing for the SCREWLINE SP 250

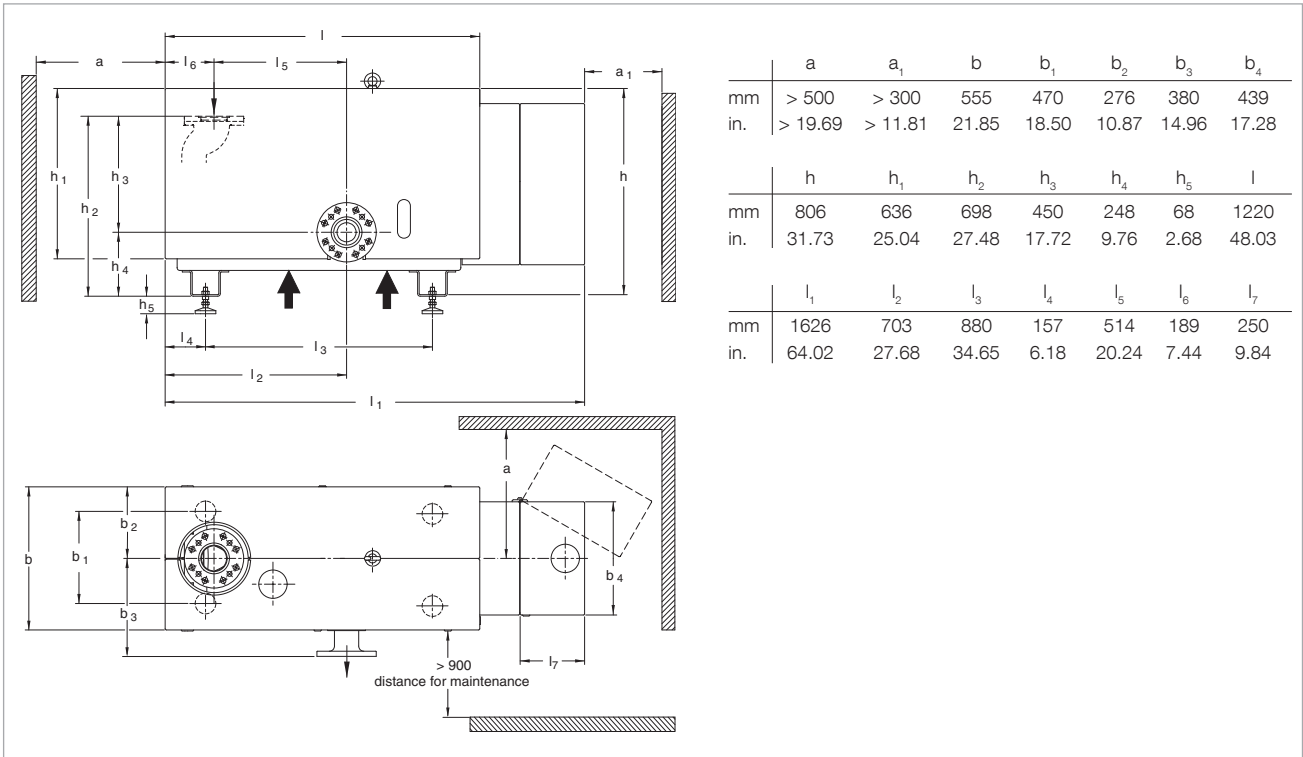

Dimensional drawing for the SCREWLINE SP 630

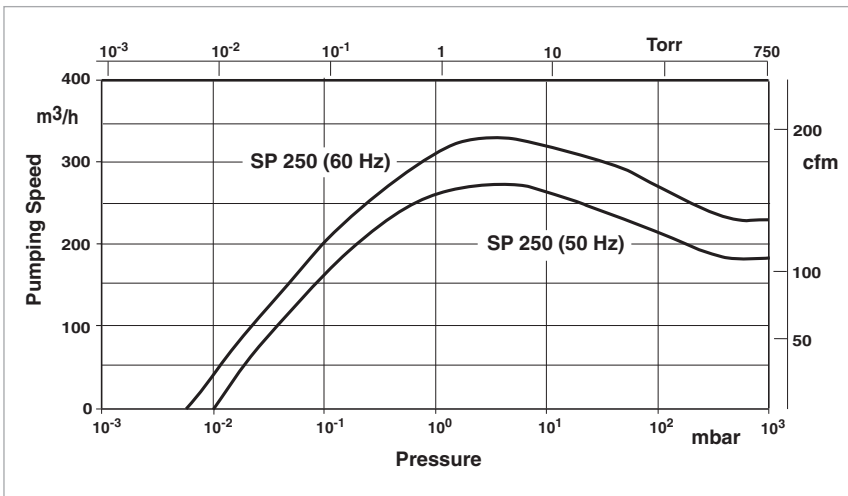

Effective pumping speed of the SCREWLINE SP 250 for air, without gas ballast (50/60 Hz)

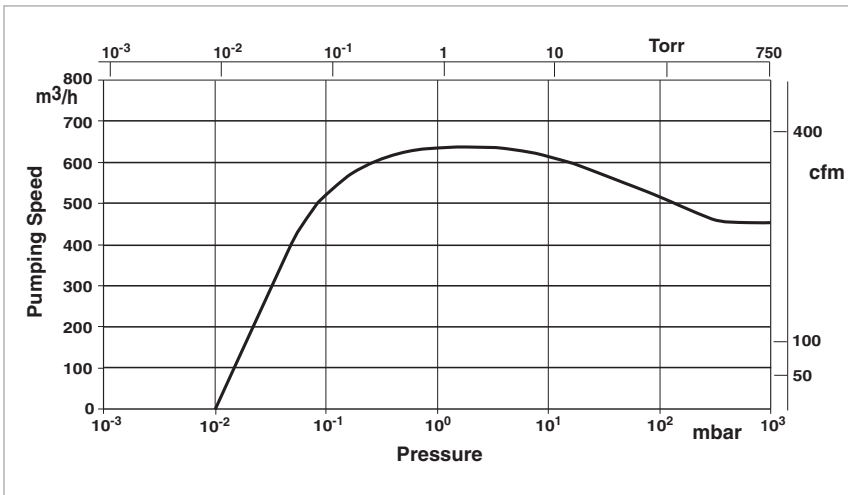

Effective pumping speed of the SCREWLINE SP 630 for air, without gas ballast

Products

Technical Data

SCREWLINE SP 250

		50 Hz	60 Hz
Effective pumping speed	m ³ x h ⁻¹ (cfm)	270 (157)	330 (194)
Ultimate pressure, total	mbar (Torr)	≤ 0.01 (≤ 0.0075)	≤ 0.005 (≤ 0.0038)
Permissible intake pressure, max.	mbar (Torr)	1030 (773)	1030 (773)
Maximum exhaust pressure with reference to the ambient pressure		$p_{ex} = p_{amb} + 200 \text{ mbar (150 Torr)}$ $- 50 \text{ mbar (37 Torr)}$	$p_{ex} = p_{amb} + 200 \text{ mbar (150 Torr)}$ $- 50 \text{ mbar (37 Torr)}$
Permissible ambient temperature	°C (°F)	+10 to +40 (+50 to +104)	+10 to +40 (+50 to +104)
Water vapour tolerance (with gas ballast)	mbar (Torr)	60 (45)	75 (56)
Water vapour capacity (with gas ballast)	kg x h ⁻¹ (gal x h ⁻¹)	10 (2.7)	18 (4.9)
Installation location		up to 3000 metres (9.800 feet) (above sea level)	up to 3000 metres (9.800 feet) (above sea level)
Cooling		Air	Air
Power supply at operating voltage	$\Delta\Delta$ Δ	32.0 A / 200 V (cos phi 0.88) 16.0 A / 400 V (cos phi 0.88)	31.5 A / 210 V (cos phi 0.88) 15.5 A / 460 V (cos phi 0.88)
Nominal power	kW (HP)	7.5 (10.0)	7.5 (10.0)
Power consumption at ultimate pressure	kW (HP) kW (HP)	5.9 (8.0) at 3-ph. 200 V / 400 V 6.5 (8.8) at 3-ph. 500 V	7.2 (9.8) at 3-ph. 200 V / 400 V -
Energy efficiency class		IE 2	IE 2
Motor rotational speed	rpm	2920	3505
Type of protection	IP	55	55
Thermal protection class		F	F
Lubricant filling (LVO 210)	l	7	7
Intake flange, standard			
Clamping flange		ISO 1609-1986 (E)-63 (DN 63 ISO-K) ¹⁾	ISO 1609-1986 (E)-63 (DN 63 ISO-K) ¹⁾
Bolt flange		ASME B 16.5 NPS 3 class 150	ASME B 16.5 NPS 3 class 150
Bolt flange		EN 1092-2-PN 6 - DN 65	EN 1092-2-PN 6 - DN 65
Exhaust flange, standard			
Clamping flange		ISO 1609-1986 (E)-63 (DN 63 ISO-K)	ISO 1609-1986 (E)-63 (DN 63 ISO-K)
Exhaust flange, optional			
Clamping flange		ISO 1609-1986 (E)-63 (DN 63 ISO-K) ¹⁾	ISO 1609-1986 (E)-63 (DN 63 ISO-K) ¹⁾
Bolt flange		ASME B 16.5 NPS 3 class 150	ASME B 16.5 NPS 3 class 150
Bolt flange		EN 1092-2-PN 16 - DN 65	EN 1092-2-PN 16 - DN 65
Bolt flange		EN 1092-2-PN 6 - DN 65	EN 1092-2-PN 6 - DN 65
Materials (components in contact with the gas)		Aluminum, aluminum anodic oxidised, C steel, CrNi steel, grey cast-iron, FPM (FKM) ((Viton))	Aluminum, aluminum anodic oxidised, C steel, CrNi steel, grey cast-iron, FPM (FKM) ((Viton))
Weight, approx.	kg (lbs)	450 (992)	450 (992)
Dimensions (W x D x H)	mm (in.)	1350 x 530 x 880 (53.1 x 20.9 x 34.6)	1350 x 530 x 880 (53.1 x 20.9 x 34.6)
Noise level ²⁾	dB(A)	67	72

¹⁾ This flange is required when ISO-K flanges are to be connected (Part No. 267 47)

²⁾ With connected exhaust gas line at ultimate pressure

Ordering Information

SCREWLINE SP 250

	Standard	ATEX	O ₂
	Part No.	Part No.	Part No.
Screw Vacuum Pump SP 250 (50/60 Hz) with manual gas ballast	115 001 ¹⁾	-	-
with purge gas unit, castors and manual gas ballast valve	115 006 ¹⁾	-	-
with electromagnetic gas ballast and purge gas unit Category 3GD IIC 160 °C (320 °F) inside	-	115 003 ^{1, 2)}	-
with electromagnetic gas ballast Purge vent vit, FFPM gaskets and purge gas unit Category 2G3D b IIC 135 °C (275 °F) inside/ Category 3GD Ex nA IIC 160 °C (320 °F) outside, (50 Hz only)	-	115 012V ¹⁾	-
with electromagnetic gas ballast and purge gas unit SP-GUARD	-	-	115 019 ^{1), 3)}
Accessories			
Exhaust silencer	119 002	119 002	119 002
Serviceable silencer	119 003V	119 003V	119 003V
Exhaust non-return valve (DN 65 PN 6)	119 011	-	-
Solenoid gas ballast kit, 24 V ⁴⁾	119 054V	-	-
Adaptor for RUVAC 501/1001	119 022	119 022	119 022
Purge gas retrofit kit	119 031	-	-
Inlet filter adapter DN 63 ISO-K	119 019	119 019	-
Dust filter	951 68	-	-
Purge vent kit	119 061V	119 061V	119 061V
Oil change kit	EK 110 000 820	EK 110 000 820	EK 110 000 820
Screw inspection kit	EK 110 000 821	EK 110 000 821 ⁵⁾	EK 110 000 821
Purge gas connection servicing kit	EK 110 000 834	EK 110 000 834	EK 110 000 834
Filter for gas ballast	E 110 000 980	E 110 000 980	E 110 000 980
Filter for purge gas valve unit	E 110 000 850	E 110 000 850	E 110 000 850
Absorbing felt	E 110 002 435	E 110 002 435	E 110 002 435
Silencer service kit	EK 500 003 476	EK 500 003 476	EK 500 003 476
Seal kit non-return valve SP 250	EK 110 000 828	EK 110 000 828	EK 110 000 828
Seal kit RUVAC adaptor SP 250	EK 110 000 835	EK 110 000 835	EK 110 000 835
Vibration element RUVAC adaptor SP 250	ES 110 000 2677	ES 110 000 2677	ES 110 000 2677

¹⁾ All pumps are equipped as standard with an SP-GUARD

²⁾ Only ATEX Category 3i (Directive 94/9/EG)

³⁾ T4 with max. $p_{ex} = p_{amb} + 200 \text{ mbar}$
- 50 mbar

⁴⁾ This accessory item can only be used beginning with SN (serial number) 31000530865

⁵⁾ Only for Part No.

For all enquiries and orders relating to category 1 and 2 ATEX products please exclusively use our ATEX questionnaire. You can find this questionnaire at the end of the full-line catalog together with the fax forms or on the Internet under "www.oerlikon.com/leyboldvacuum" under Download Documents in the area Documentation.

SCREWLINE SP 630

Technical Data

50 Hz

60 Hz

Effective pumping speed	$\text{m}^3 \times \text{h}^{-1}$ (cfm)	630 (371)	630 (371)
Ultimate total pressure	mbar (Torr)	≤ 0.01 (≤ 0.0075)	≤ 0.01 (≤ 0.0075)
Intake pressure limits, max.	mbar (Torr)	1030 (773)	1030 (773)
Maximum exhaust pressure with reference to the ambient pressure		$p_{\text{ex}} = p_{\text{amb}} + 200 \text{ mbar (150 Torr)}$ $- 50 \text{ mbar (37 Torr)}$	$p_{\text{ex}} = p_{\text{amb}} + 200 \text{ mbar (150 Torr)}$ $- 50 \text{ mbar (37 Torr)}$
Permissible ambient temperature	$^{\circ}\text{C}$ ($^{\circ}\text{F}$)	+10 to +40 (+50 to +104)	+10 to +40 (+50 to +104)
Water vapour tolerance (with gas ballast)	mbar (Torr)	40 (30)	40 (30)
Water vapour capacity (with gas ballast)	$\text{kg} \times \text{h}^{-1}$ (gal \times h^{-1})	14 (3.7)	14 (3.7)
Installation location		up to 3000 metres (9.800 feet) (above sea level)	up to 3000 metres (9.800 feet) (above sea level)
Cooling		Air	Air
Power supply	$\Delta\Delta$ Δ ¹⁾ Y	56 A / 200 V 28 A / 400 V 16 A / 690 V	52 A / 210 V 24 A / 460 V -
$\cos \varphi$		0.89	0.90
Nominal power	kW (HP)	15 (20)	15 (20)
Power consumption at ultimate pressure	kW (HP)	< 11 (< 15)	< 11 (< 15)
Energy efficiency class		IE 2	IE 2
Motor rotational speed	rpm	2930	3530
Type of protection	IP	55	55
Thermal protection class		F	F
Lubricant filling (LVO 210)	l	13	13
Intake flange and exhaust flange compatible with bolt flanges		EN 1092-2 - PN 6 - DN 100 EN 1092-2 - PN 16 - DN 100 ISO 1609-1986 (E)-100 (DN 100 ISO-K) ²⁾ ASME B 16.5 NPS4 class 150	EN 1092-2 - PN 6 - DN 100 EN 1092-2 - PN 16 - DN 100 ISO 1609-1986 (E)-100 (DN 100 ISO-K) ²⁾ ASME B 16.5 NPS4 class 150
Materials (components in contact with the gas)		Aluminum, aluminum anodic oxidised, C steel, CrNi steel, grey cast-iron, FPM (FKM) ((Viton))	Aluminum, aluminum anodic oxidised, C steel, CrNi steel, grey cast-iron, FPM (FKM) ((Viton))
Weight, approx.	kg (lbs)	530 (1166)	530 (1166)
Dimensions (W x D x H)	mm (in.)	1630 x 660 x 880 (64 x 26 x 35)	1630 x 660 x 880 (64 x 26 x 35)
Noise level ³⁾	dB(A)	73	75

¹⁾ 690 V upon request

²⁾ This flange is required when ISO-K flanges are to be connected (Part No. 267 50)

³⁾ With connected exhaust gas line at ultimate pressure

SCREWLINE SP 630 F

Additional Technical Data

50 Hz

60 Hz

Cooling		Water	Water
Water connection	G	1/2" ISO 228-1	1/2" ISO 228-1
Water temperature	$^{\circ}\text{C}$ ($^{\circ}\text{F}$)	+5 to +35 (+41 to +95)	+5 to +35 (+41 to +95)
Minimum water feed pressure	bar (psi, gauge)	2 (15)	2 (15)
Nominal flow at a water feed temperature of 25° C (77 °F)	l/min (gal/min)	12 (3)	12 (3)
Noise level ¹⁾	dB(A)	71	71

¹⁾ With connected exhaust gas line at ultimate pressure

Ordering Information**SCREWLINE SP 630 Standard / SP 630 F Standard**

	50 Hz	60 Hz
	Part No.	Part No.
Screw Vacuum Pump SP 630 air cooled, with manual gas ballast	117 007	117 008
Screw Vacuum Pump SP 630 F water cooled, with adapter for RUVAC 2001 and electromagnetic gas ballast	117 105	117 106
with manual gas ballast	117 107	117 108
with purge gas kit and manual gas ballast	117 113	117 114
Screw Vacuum Pump SP 630 S1 water cooled, with castors, purge gas kit and electromagnetic gas ballast	117 117	117 118

All pumps are equipped as standard with an SP-GUARD

Ordering Information**SCREWLINE SP 630 ATEX / SP 630 F ATEX**

	50 Hz	60 Hz
	Part No.	Part No.
Screw Vacuum Pump SP 630 with purge gas kit 24 V gas ballast and water cooled, Category 3G IIC (160 °C (320 °F)) inside	117 017	117 018
with purge gas kit and manual gas ballast, Category 3G IIC (160 °C (320 °F)) inside	117 115	117 116
Screw Vacuum Pump SP 630 F water cooled Category 2G3D IIC (160 °C (320 °F)) Category 3G IIC T3 (160 °C (320 °F)) with purge gas monitor, adapter for RUVAC 2001 and electromagnetic gas ballast	117 111	117 112

All pumps are equipped as standard with an SP-GUARD

For all enquiries and orders relating to category 1 and 2 ATEX products please exclusively use our ATEX questionnaire. You can find this questionnaire at the end of the full-line catalog together with the fax forms or on the Internet under "www.oerlikon.com/leyboldvacuum" under Download Documents in the area Documentation.

Ordering Information**SP 630 O₂**

	50 Hz	60 Hz
	Part No.	Part No.
Screw Vacuum Pump SP 630 with purge gas monitor and electromagnetic gas ballast	117 039	117 040

All pumps are equipped as standard with an SP-GUARD

Ordering Information

SCREWLINE SP 630 Standard / SP 630 F Standard

Accessories

50 Hz / 60 Hz

	Part No.
Exhaust silencer	119 001
Serviceable silencer	119 004V
Roots pump adapter for RUVAC 1001 ¹⁾ for RUVAC 2001 for RUVAC WH 4400	500 003 173 119 021 119 024V
Dust filter ²⁾ Elbow 90° (DN 100 ISO-K) Clamping screws for DN 63-250 ISO-K Centering ring for DN 100 ISO-K	951 72 887 26 267 01 268 06
Purge vent Kit	119 060V
Inlet filter adapter DN 100 ISO-K	119 020
Solenoid gas ballast kit, 24 V from serial number 31000530865	119 054V
Non-return valve (DN 100 PN 6)	119 010
Purge gas retrofit kit ³⁾	119 030
Maintenance kit, level 1 (oil change kit) up to serial number 31000197911 from serial number 31000197911	EK 110 000 792 EK 110 000 832
Maintenance kit, level 2 (rotor inspection kit)	EK 110 000 793
Purge gas connection servicing kit	EK 110 000 827
Filter for gas ballast	E 110 000 980
Filter for purge gas valve unit	E 110 000 850
Water filter maintenance kit for SP 630 F	EK 110 000 813
Silencer service kit	EK 500 003 475
Seal kit for SP 630 check valve	EK 110 000 815

¹⁾ Must mount to adapter Part No. 119 021

²⁾ For information on the dust filter please refer to the Catalog Part "Oil sealed Vacuum Pumps", Section "SOGEVAC", Chapter "Accessories"

³⁾ Not for ATEX pumps

General

Applications for DRYVAC Pumps

Pumps	DRYVAC DV 450	DRYVAC DV 450 S	DRYVAC DV 450 C	DRYVAC DV 650	DRYVAC DV 650-r	DRYVAC DV 650 S	DRYVAC DV 650 S-i	DRYVAC DV 650 C	DRYVAC DV 650 C-r	DRYVAC DV 650 C-i	DRYVAC DV 1200	DRYVAC DV 1200 S-i	DRYVAC DVR 5000 C-i
Application													
Automotive industry	■			■	■					■			
Electrical engineering	■			■	■					■			
Energy technology			■	■	■		■	■	■	■			
Degassing	■			■	■					■			
Research and development	■		■	■	■		■	■	■	■			■
Freeze drying	■		■	■	■		■	■	■	■			■
Industrial gases	■		■	■	■		■	■		■			
Refrigeration and air conditioning	■			■	■					■			
Crystal pulling/casting	■		■	■	■		■	■	■	■			■
Lamination	■			■	■		■	■	■	■			■
Leak testing machines	■	■		■	■	■	■			■	■		
Loadlock chambers		■				■	■					■	
Metallurgy/Furnaces	■			■	■					■			
Plasma cleaning or activation	■		■	■	■		■	■	■	■			■
Welding technology	■	■		■	■	■	■			■	■		
Sterilization			■				■	■	■				■
Vacuum coating			■				■	■	■				■
Vacuum drying	■	■		■	■	■	■			■	■		
Packaging	■			■	■					■			
Space simulation	■			■	■					■			
Wind turbines	■			■	■					■			
Backing pump for Highvacuum systems	■			■	■					■			

Oil for DRYVAC pumps for different fields of application

Applications	Automotive industry	Electrical engineering	Energy technology	Degassing	Research and development	Freeze drying	Industrial gases	Refrigeration and air conditioning	Crystal pulling/casting	Lamination	Leak testing	Loadlock machines	Metallurgy/Furnaces	Plasma cleaning or activation	Welding technology	Sterilization	Vacuum coating	Vacuum drying	Packaging	Space simulation	Wind turbines	Backing pump for Highvacuum systems	
LEYBONOL Oils																							
LVO 210	■	■	■	■	■	■	■	■	●	●	■	■	■	■	■	■	■	■	■	■			
LVO 410			●		●		●	■	■	●	■					■		●	●	■		■	

- = Standard
- = Possible

The table only lists general applications. Your specific requirements might be subject to deeper analysis. For further questions, please contact our technical Sales support.

For information on oil specifications please refer to Catalog Part "Oils / Greases / Lubricants LEYBONOL®".

Oil for DRYVAC pumps for different pump types

Pumps	DRYVAC DV 450	DRYVAC DV 450 S	DRYVAC DV 450 C	DRYVAC DV 650	DRYVAC DV 650-r	DRYVAC DV 650 S	DRYVAC DV 650 S-i	DRYVAC DV 650 C	DRYVAC DV 650 C-r	DRYVAC DV 650 C-i	DRYVAC DV 1200	DRYVAC DV 1200 S-i	DRYVAC DVR 5000 C-i
LEYBONOL Oils													
LVO 210	■		■	■						■			
LVO 410		■	■			■	■	■	■	■		■	■

■ = Standard

The table only lists general applications. Your specific requirements might be subject to deeper analysis.
For further questions, please contact our technical Sales support.

**For information on oil specifications please refer to Catalog Part
"Oils / Greases / Lubricants LEYBONOL®".**

General

DRYVAC DV 450 to DVR 5000 C-i

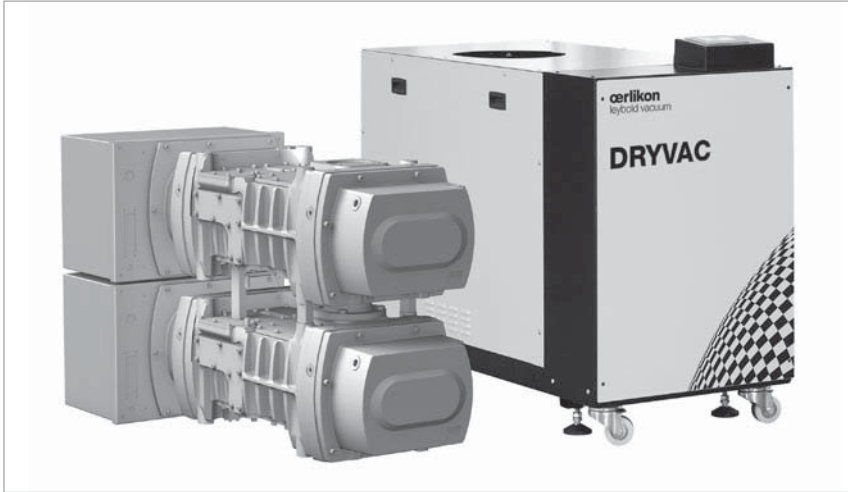

DRYVAC series

The Benefits of the Screw Principle

The direct pumping path without multiple deflections of the gas makes the DRYVAC vacuum pumps very insensitive to foreign materials. This ensures a high reliability in industrial processes. The straight and short path for the gas from the inlet of the pump to its exhaust reduces the dwell time of the gas and thereby reduces potential deposits within the pump. Through the use of a purge gas (e.g. gas ballast), any deposits, particles and condensates can be effectively removed.

Just like the Screw Vacuum Pump SP, the DRYVAC was developed for demanding applications. However, the range of applications is extended by the DRYVAC to include numerous photovoltaic and display production processes. A unique characteristic of the Screw Vacuum Pump series SCREWLINE is the availability of air cooling and the low internal surface temperatures allowing applications like lamination, for example, to be run with long uptimes and low maintenance complexity.

DRYVAC is a new family of dry compressing screw vacuum pumps available with different features depending on the specific application. The DRYVAC family was developed in consideration of the special requirements of the photovoltaic, display and process industries. All DRYVAC variants are water cooled, very compact and easy to combine into systems, in particular with the well-proven Roots pumps of the RUVAC WH, WS and WA series.

Certifications

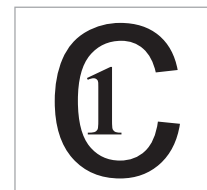
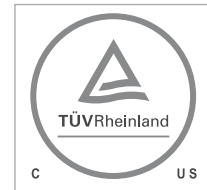

The Best DRYVAC for every Application

The DRYVAC standard version and the DRYVAC DV S deliver an optimized pumping speed also pressures exceeding 100 mbar. DV and DV S types are suited for short cycle operation (load locks, for example) or for the evacuation of large vacuum chambers.

The DRYVAC pumps are equipped with all features necessary for process industry applications (gas ballast, for example).

The DRYVAC DV C models offer reliability in connection with harsh processes. They have been optimized for pumping media typically employed in photovoltaic and flat screen production processes. The DRYVAC DV C offers a high pumping speed for hydrogen and owing to its integrated purge gas system is insensitive to dust.

Main features and customer benefits offered by the DRYVAC are the compact design, the low-profile and the option of being able to easily build horizontally arranged pump systems and the power consumption reduced by up to 30% compared to screw pumps of the 630 m³/h pumping speed class.

These DRYVAC variants are available in different configuration levels: In the case of the DRYVAC-r the frequency converter has been designed for integration within an external electrical cabinet whereas in the case of the other variants the frequency converter has been integrated within the pump. The DRYVAC-i versions expand the DRYVAC by a PLC with a touch screen display and a software user interface allowing easy operation and configuration. The S-i versions are linked to the system as standard through a Profibus or a 24 V I/O interface (other interfaces upon request). Additionally, the S-i versions are accommodated in a full enclosure with castors, height adjustable feet and Harting socket.

The DRYVAC DV 450 and DV 650 pumps are equipped with one screw pumping stage, the DRYVAC 1200 is equipped with two pump stages running in parallel.

The DRYVAC DVR 5000 C-i is a special variant of the DRYVAC-i. This process pump is an autonomously controlled combination consisting of a DRYVAC DV 650 C screw pump and a new member of the RUVAC WH series, the WH 2500. Just like the screw pump, the RUVAC is also operated and controlled by a frequency converter (100 Hz max.) The effective pumping speed of the combination amounts to approximately 3800 m³/h for nitrogen.

Design Features of the DRYVAC Family

- Water cooled
- Hermetically sealed screw and Roots pumps, static seals only towards the outside
- Simple mechanical and electrical integration
- Integrated protection function via temperature, exhaust pressure and current consumption
- Small footprint
- Low energy consumption due to optimized rotor geometry and innovative motor design meeting IE2 efficiency class requirements
- Wide voltage and frequency range: 380-460 V, 50/60 Hz
- NRTL certified

Typical Applications

- Solar coating (SiN, ZnO, a-Si/ μ -Si, CdTe, CIS/CIGS, etc.)
- Load lock
- Polysilicon production
- Display and glass coating
- Wear protection coating
- Strip coating
- Furnaces
- Metallurgy
- Vacuum drying
- Electron beam welding
- Food & Packaging

The Benefits at a Glance

- Most compact dry pump, with the smallest footprint for pump systems
- Optimized Cost of Ownership including the lowest power consumption available on the market today
 - Utmost package flexibility
 - Low noise level
 - Highest reliability
 - Integrated self-monitoring and control
 - No unscheduled down times, minor maintenance demands

The DRYVAC series

comprises the models

- DRYVAC DV 450
- DRYVAC DV 450-r
- DRYVAC DV 450-i
- DRYVAC DV 650
- DRYVAC DV 650-i
- DRYVAC DV 650-r
- DRYVAC DV 650 Atex Kat. 2
- DRYVAC DV 1200
- DRYVAC DV 1200 S-i
- DRYVAC DV 1200 Atex Kat. 2
- DRYVAC DVR 5000-i
- DRYVAC DVR 5000 C-i
- DRYVAC DVR 5000 S-i

and allows for numerous combinations with Roots pumps from the RUVAC series.

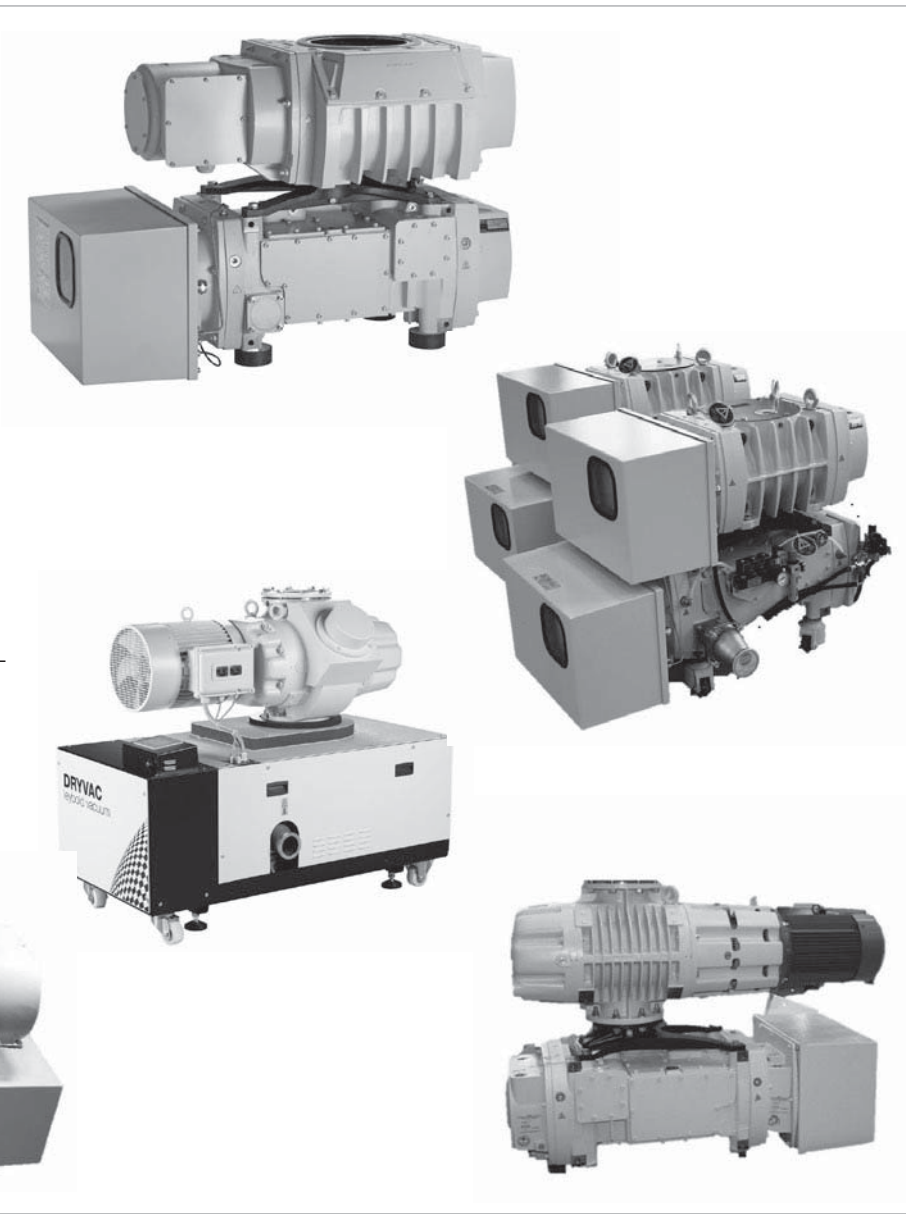

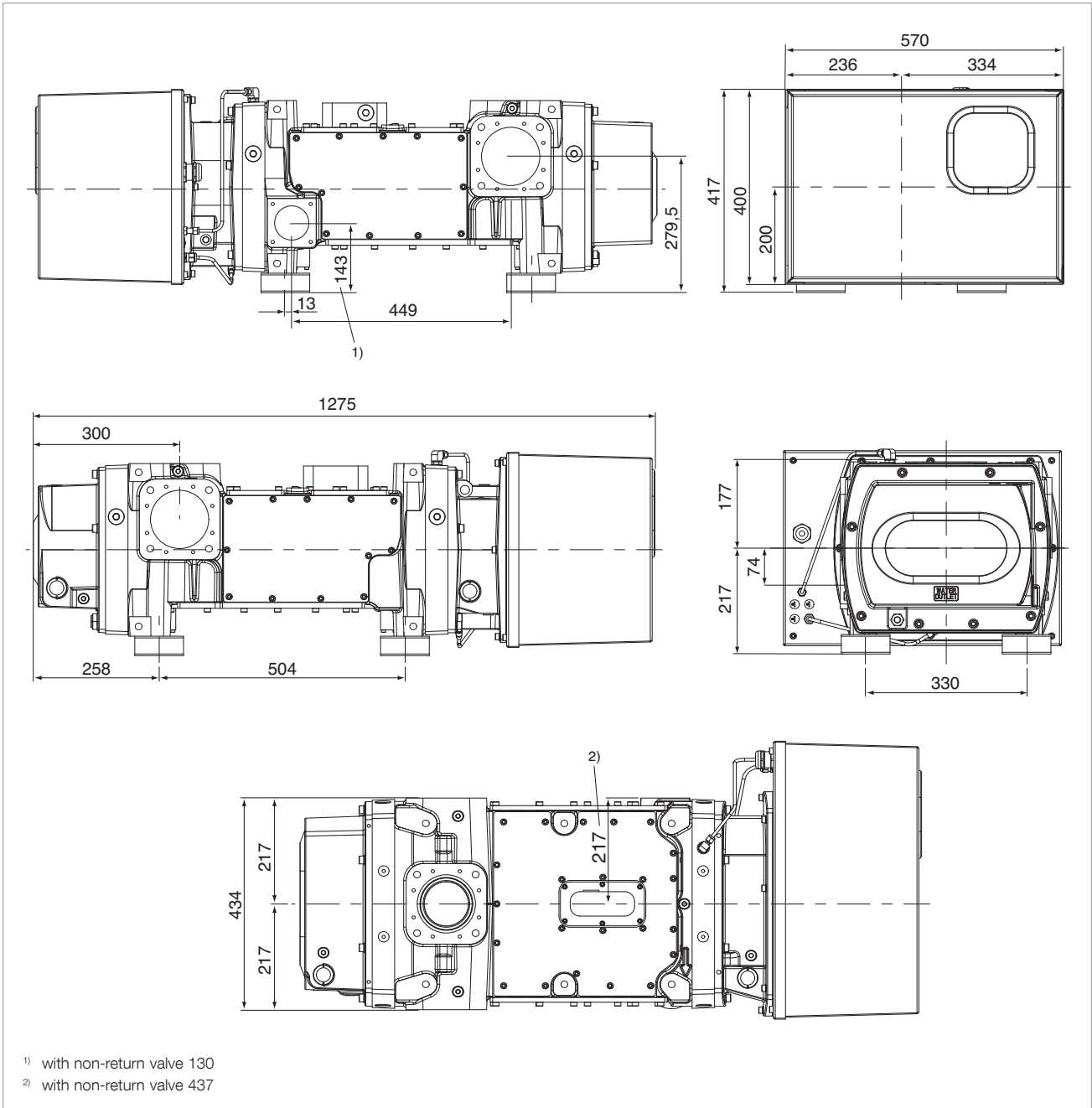

Dimensional drawing for the DRYVAC DV 450 and DV 650

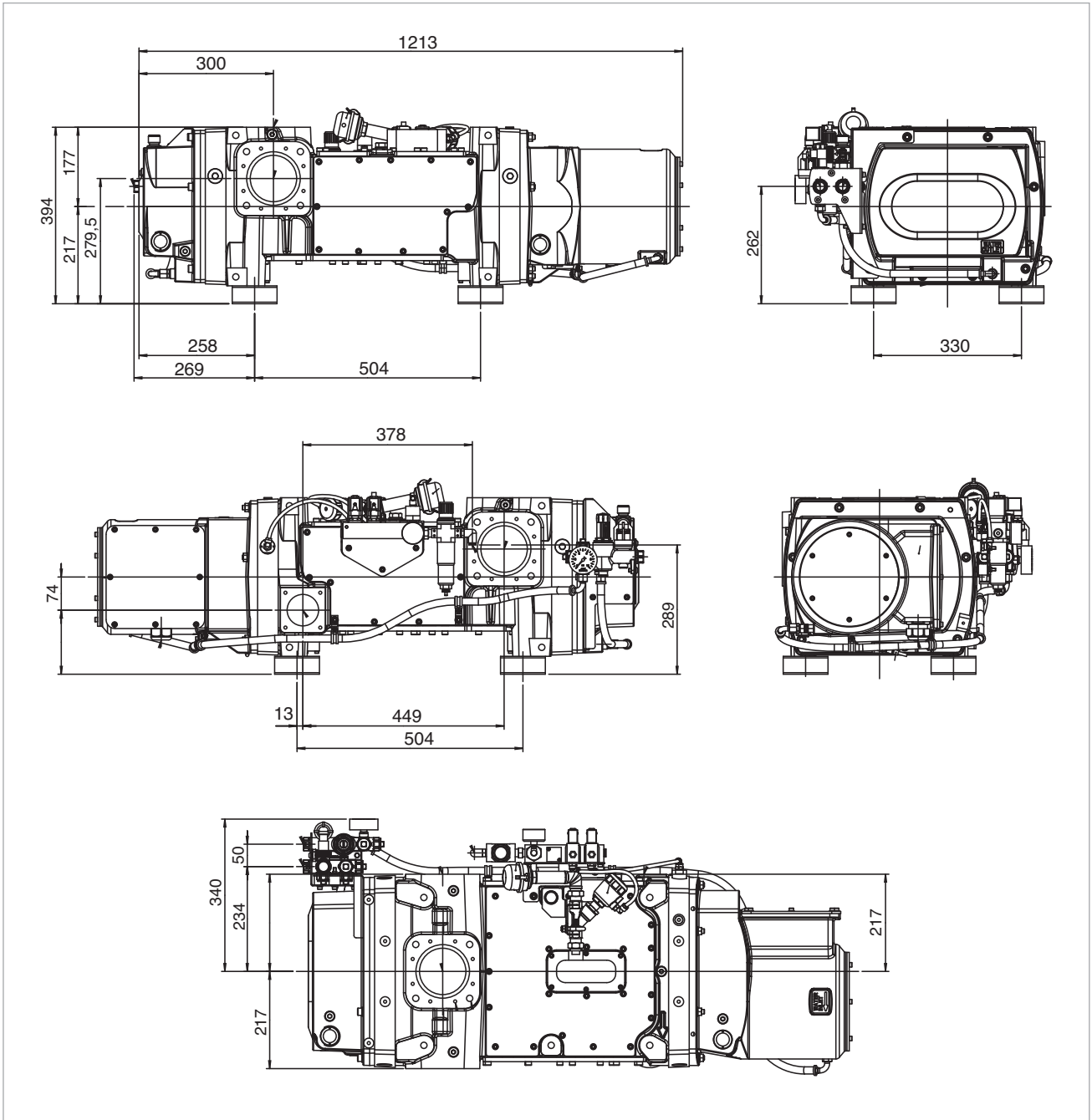

Dimensional drawing for the DRYVAC DV 450-r and DV 650-r

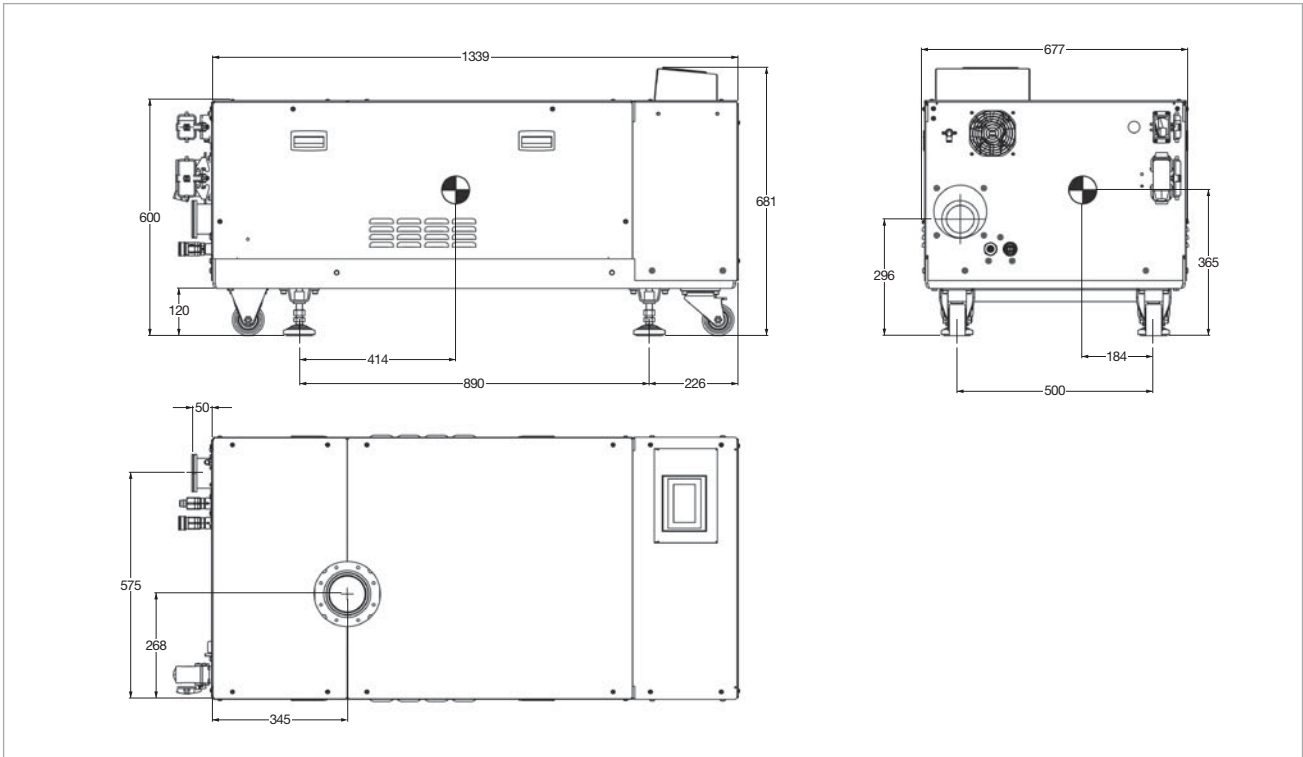

Dimensional drawing for the DRYVAC DV 450-i and DV 650-i

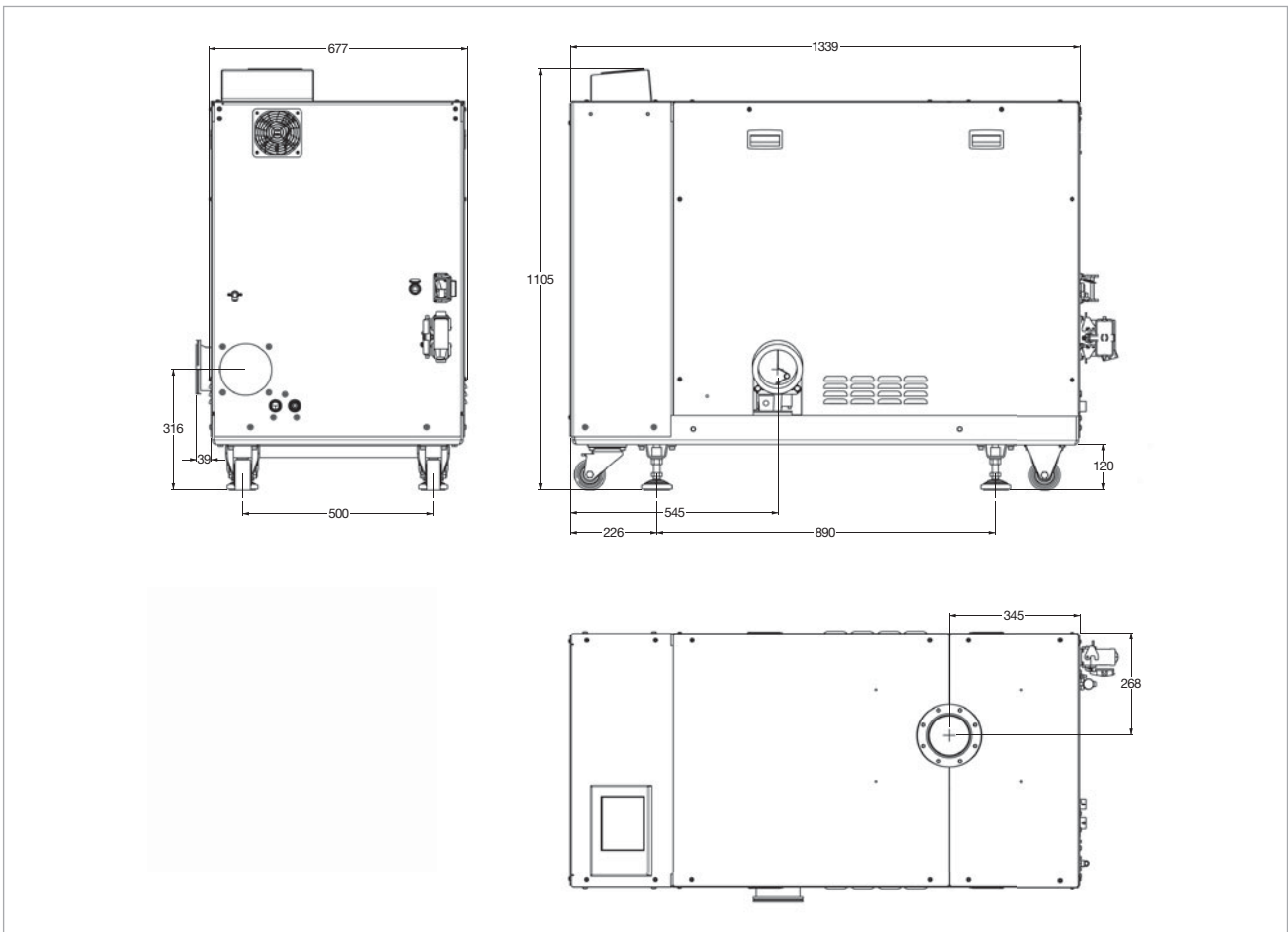

Dimensional drawing for the DRYVAC DV 1200 S-i

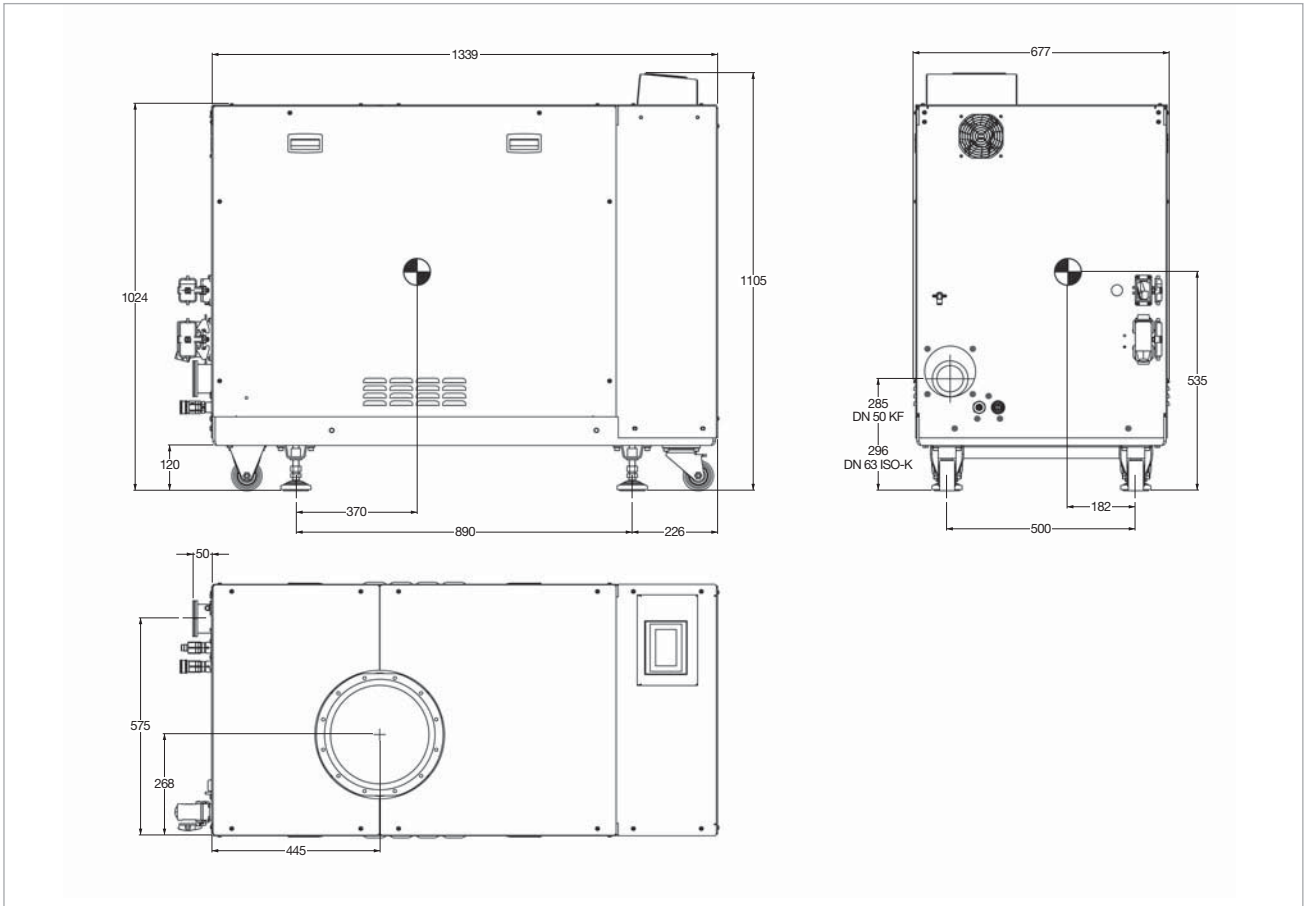

Dimensional drawing for the DRYVAC DVR 5000-i, 5000 C-i and 5000 S-i

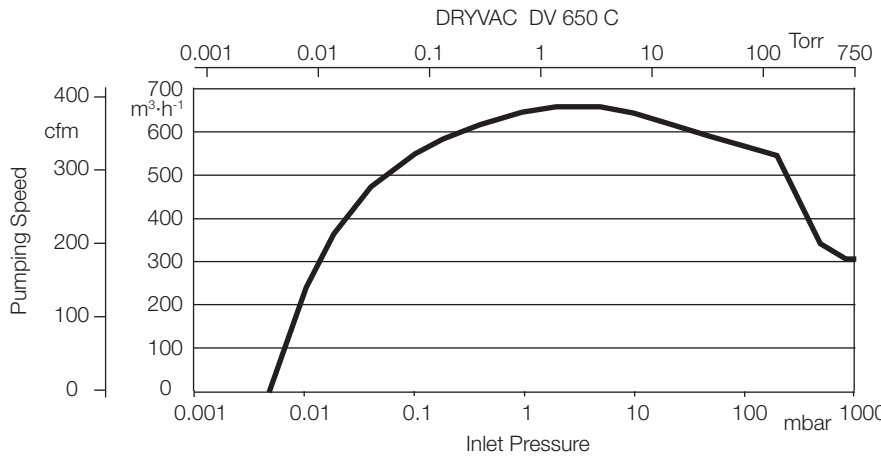
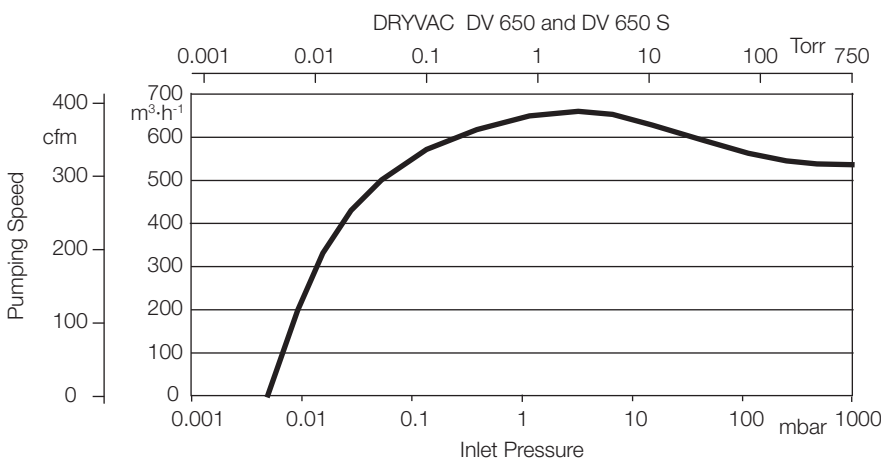
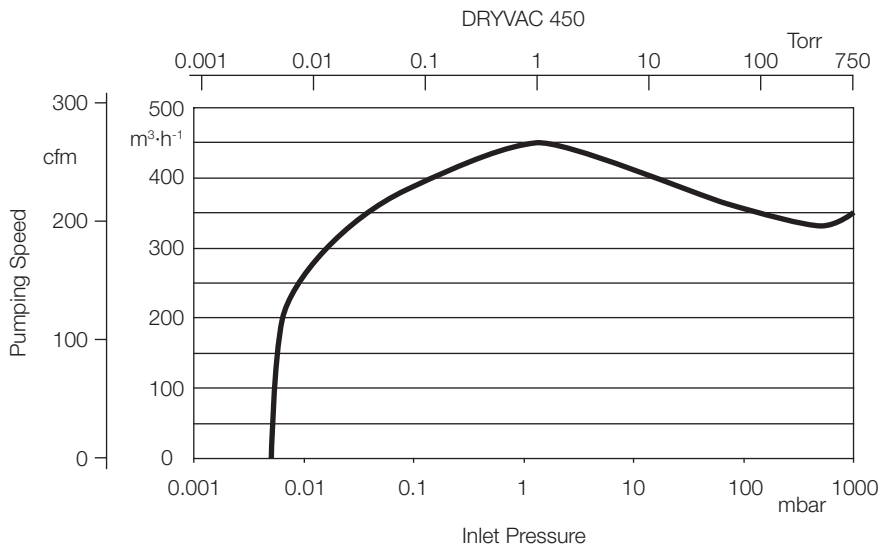

Pumping speed curves of the DRYVAC DV 450, DV 650 (S) and DRYVAC DV 650 C

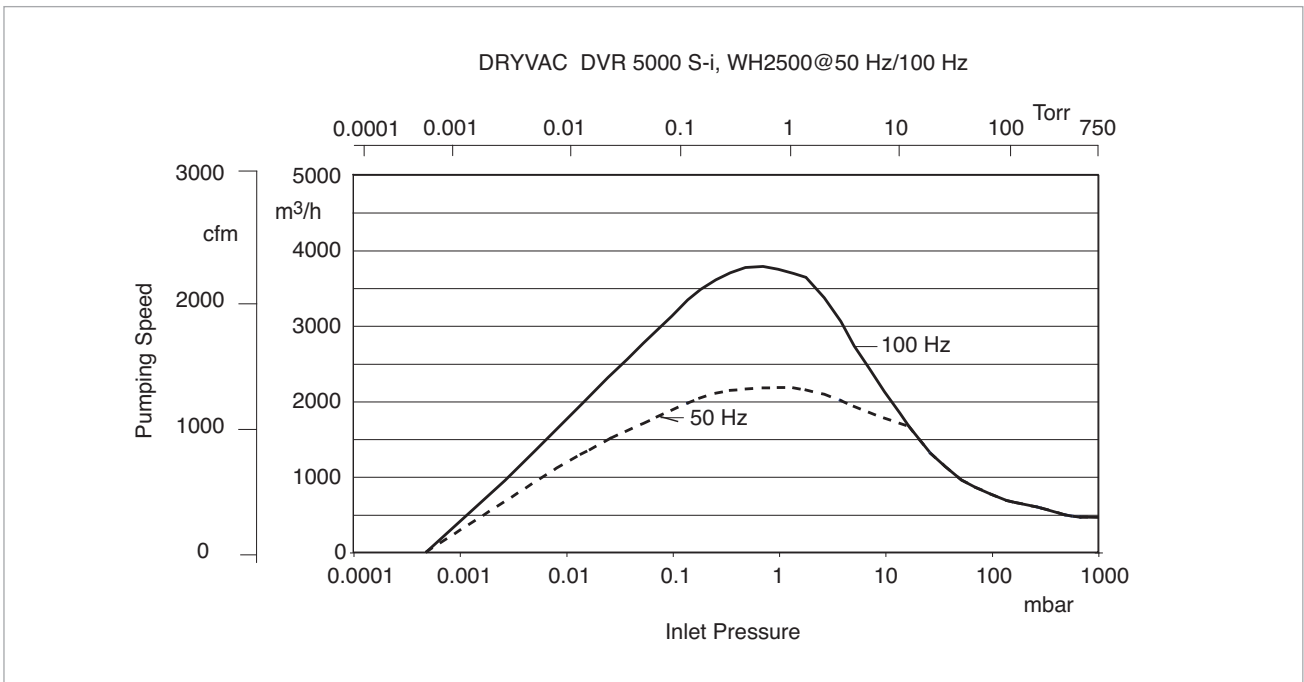

Pumping speed curves of the DRYVAC DVR 5000 S-i

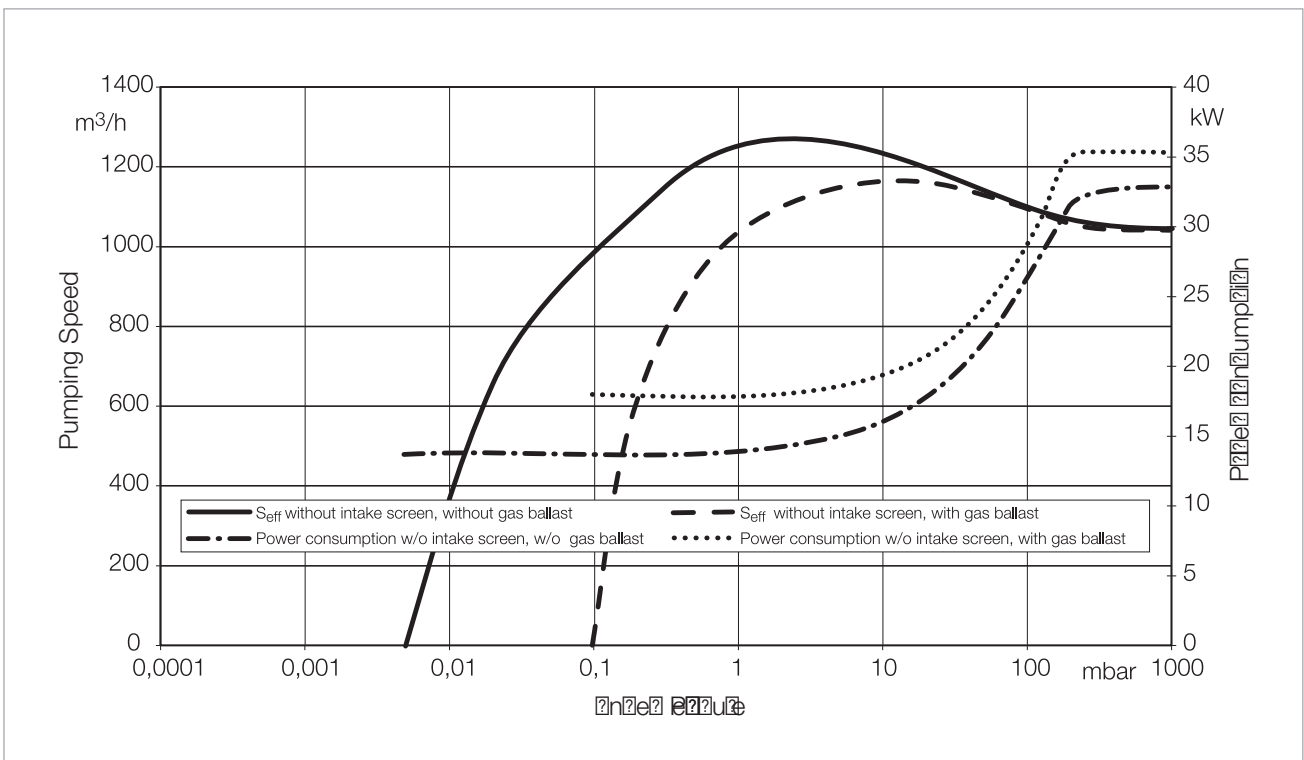

Pumping speed curves of the DRYVAC DV 1200 and DV 1200 S-i

Products

Technical Data

DRYVAC DV / DV S / DV C

		450	650-i	650	650-r
Nominal pumping speed	m ³ /h (cfm)	450 (265)	650 (383)	650 (383)	650 (383)
Max. effective pumping speed	m ³ /h (cfm)	450 (265)	650 (383)	650 (383)	650 (383)
Ultimate pressure	mbar (Torr)	5 x 10 ⁻³ (4 x 10 ⁻³)	5 x 10 ⁻³ (4 x 10 ⁻³)	5 x 10 ⁻³ (4 x 10 ⁻³)	5 x 10 ⁻³ (4 x 10 ⁻³)
Permissible ambient temperature	°C (°F)	+5 to +50 (+41 to +122)	+5 to +40 (+41 to +104)	+5 to +50 (+41 to +122)	+5 to +50 (+41 to +122)
Water vapour tolerance with > 20 slm purge gas or gas ballast	mbar (Torr)	60 (45)	60 (45)	60 (45)	60 (45)
Water vapour capacity	kg/h	15	25	25	25
Noise level at ultimate pressure with silencer and exhaust line	dB(A)	67	65	67	67
with permanent exhaust line	dB(A)	65	65	65	65
Power consumption at ultimate pressure	kW	5.3	≤ 7	≤ 7	≤ 7
Cooling		water	water/air	water	water
Electrical connection		380-460 V, 50/60 Hz	380-460 V, 50/60 Hz	380-460 V, 50/60 Hz	380-460 V, 50/60 Hz
Phases		3-ph.	3-ph.	3-ph.	3-ph.
Nominal power at 400 V	kW	11	15	15	15
Nominal current at 400 V	A	24	31	31	31
Intake connection	DN	100 ISO-K PN6 (1x at the top, 2x at the side)	100 ISO-K	100 ISO-K PN6 (1x at the top, 2x at the side)	100 ISO-K PN6 (1x at the top, 2x at the side)
Exhaust side connection	DN	63 ISO-K	63 ISO-K	63 ISO-K	63 ISO-K
Protection class EN 60529	IP	54	20	54	55
Weight	kg (lbs)	620	750 (1654)	580 (1280)	540 (1192)
Dimensions (W x D x H)	mm (in.)	1280 x 570 x 420 (50.4 x 22.4 x 16.5)	1370 x 677 x 681 (52.8 x 26.7 x 26.8)	1280 x 570 x 420 (50.4 x 22.4 x 16.5)	1200 x 450 x 400 (47.2 x 17.7 x 15.7)
Cooling water connection Threads, female	G	1/2	1/2	1/2	1/2
Cooling water temperature with gear oil LEYBONOL LVO 210	°C (°F)	5 to 35 (41 to 95)	5 to 35 (41 to 95)	5 to 35 (41 to 95)	5 to 35 (41 to 95)
with gear oil LEYBONOL LVO 410	°C (°F)	5 to 25 (41 to 77)	5 to 25 (41 to 77)	5 to 25 (41 to 77)	5 to 25 (41 to 77)
Cooling water throughput, nominal	l/min (US gallon/min)	6 (1.6)	7.5 (2.0)	7.5 (2.0)	7.5 (2.0)
Purge gas connection (plugged connection)		D10	D10	D10	D10

Technical Data

DRYVAC DV / DV S / DV C

		1200-i	1200	DVR 5000-i
Nominal pumping speed	m ³ /h (cfm)	1250 (736)	1250 (736)	5000 (2945)
Max. effective pumping speed	m ³ /h (cfm)	1250 (736)	1250 (736)	3800 (2238)
Ultimate pressure (Torr)	mbar	5 x 10 ⁻³ (4 x 10 ⁻³)	5 x 10 ⁻³ (4 x 10 ⁻³)	5 x 10 ⁻⁴ (4 x 10 ⁻⁴)
Permissible ambient temperature	°C (°F)	+5 to +40 (+41 to +104)	+5 to +50 (+41 to +122)	+5 to +40 (+41 to +104)
Water vapour tolerance with > 20 slm purge gas or gas ballast	mbar (Torr)			60 (45)
with > 40 slm purge gas or gas ballast	mbar (Torr)	60 (45)	60 (45)	
Water vapour capacity	kg/h	50	50	25
Noise level at ultimate pressure with silencer and exhaust line	dB(A)	65	67	67
with permanent exhaust line	dB(A)	65	65	67
Power consumption at ultimate pressure	kW	≤ 14	≤ 14	≤ 9.5
Cooling		water/air	water	water/air
Electrical connection		380-460 V, 50/60 Hz	380-460 V, 50/60 Hz	380-460 V, 50/60 Hz
Phases		3-ph.	3-ph.	3-ph.
Nominal power at 400 V	kW	30	30	21
Nominal current at 400 V	A	62	62	35
Intake connection	DN	100 ISO-K	100 ISO-K	250 ISO-K
Exhaust side connection	DN	100 ISO-K	100 ISO-K	63 ISO-K or 50 KF
Protection class EN 60529	IP	20	54	20
Weight	kg (lbs)	1400 (3091)	1400 (3091)	1200 (2646)
Dimensions (W x D x H)	mm (in.)	1370 x 677 x 1105 (53.9 x 26.7 x 43.5)	1370 x 677 x 1105 (53.9 x 26.7 x 43.5)	1370 x 677 x 1105 (53.9 x 26.7 x 43.5)
Cooling water connection Threads, female	G	1/2	1/2	1/2
Cooling water temperature with gear oil LEYBONOL LVO 210	°C (°F)	5 to 35 (41 to 95)	5 to 35 (41 to 95)	5 to 35 (41 to 95)
with gear oil LEYBONOL LVO 410	°C (°F)	5 to 25 (41 to 77)	5 to 25 (41 to 77)	5 to 25 (41 to 77)
Cooling water throughput, nominal	l/min (US gallon/min)	15.0 (4.0)	15.0 (4.0)	11.0 (2.9)
Purge gas connection (plugged connection)		D10	D10	D10

Ordering Information

DRYVAC DV / DV S / DV C

DRYVAC	PLC/Touch Screen/ Software	Frequency converter	Purge module	Gas ballast module (ambient air)	Housing and feet	Lubricant LEYBONOL	Part No.
DV							
450-r, 400 V	no	external (rack)	triple	none	rubber feet	LVO 210	112045V07-1
450, 400 V	no	on board	double	24 V valve	rubber feet	LVO 210	112045V15-1
450, 200 V	no	on board	double	24 V valve	rubber feet	LVO 210	112045V19-1
450-i, 400 V	yes	on board	triple	none	housing, castors, adjustable feet	LVO 210	112045V50-1
650-r, 400 V	no	external (rack)	double	24 V valve	rubber feet	LVO 210	112065V05-1
650-r, 200 V	no	external (rack)	double	24 V valve	rubber feet	LVO 210	112065V19-1
650, 400 V ATEX Cat. 2i	no	on board	double	24 V valve	rubber feet	LVO 210	112065V11-1
650, 400 V	no	on board	double	24 V valve	rubber feet	LVO 210	112065V15-1
650, 400 V	no	on board	triple	none	rubber feet	LVO 210	112065V17-1
650-i, 400 V	yes	on board	triple	none	housing, castors, adjustable feet	LVO 210	112065V50-1
1200, 400 V ATEX Cat. 2i	no	on board	double	24 V valve	housing, castors, adjustable feet	LVO 210	112120V11-1
1200, 400 V with Profibus	no	on board (2x)	double	24 V valve	housing, castors, adjustable feet	LVO 210	112120V17-1
1200-i, 400 V	yes	on board	triple	none	housing, castors, adjustable feet	LVO 210	112120V50-1
DV S							
450 S, 400 V	no	on board	single	none	rubber feet	LVO 210	112045V09-1
450 S, 400 V	no	on board	single	none	rubber feet	LVO 410	112045V20-1
450 S, 200 V	no	on board	single	none	rubber feet	LVO 410	112045V29-1
650 S, 400 V	no	on board	single	none	rubber feet	LVO 210	112065V09-1
650 S, 400 V	no	on board	single	none	rubber feet	LVO 410	112065V20-1
650 S-r, 400 V	no	external (rack)	double	none	rubber feet	LVO 410	112065V23-1
650 S-i, 400 V	yes	on board	triple	none	housing, castors, adjustable feet	LVO 410	112065V40-1
1200 S-i, 400 V	yes	on board	triple	none	housing, castors, adjustable feet	LVO 410	112120V40-1
DV C							
450 C, 400 V	no	on board	triple	none	rubber feet	LVO 410	112045V30-1
650 C, 400 V	no	on board	triple	none	rubber feet	LVO 410	112065V30-1
650 C-r, 200 V	no	external (rack)	triple	none	rubber feet	LVO 410	112065V35-1
650 C-r, 400 V with relay option board	no	external (rack)	triple	none	rubber feet	LVO 410	112065V36-1
650 C-i, 400 V	yes	on board	triple	none	housing, castors, adjustable feet	LVO 410	112065V45-1
DVR							
5000-i, 400 V	yes	on board	triple	none	housing, castors, adjustable feet	LVO 210	112500V50-1
5000 C-i, 400 V Exhaust connection DN 63 ISO-K	yes	on board	triple	none	housing, castors, adjustable feet	LVO 410	112500V45-1
5000 C-i, 400 V Exhaust connection DN 50 ISO-KF	yes	on board	triple	none	housing, castors, adjustable feet	LVO 410	112500V60-1
5000 S-i, 400 V	yes	on board	triple	none	housing, castors, adjustable feet	LVO 410	112500V40-1

Ordering Information

Accessories

	Part No.
Profibus module for DRYVAC DV / DV-r	155212V
ProfiNet module for DRYVAC DV / DV-r	112005A35
EtherCAT module for DRYVAC DV / DV-r	112005A36
Relay module (digital output) for DRYVAC DV / DV-r	112005A01
Ethernet interface board for DRYVAC DV / DV-r	112005A02
Interface kit 24 Volt I/O for DRYVAC DV / DV-r	112005A22
Adapter DRYVAC for RUVAC WH 700	112005A03
RUVAC WS(U) 1001	112005A04
RUVAC WS(U) 2001	112005A05
RUVAC WH(U) 2500	112005A07
RUVAC WH(U) 4400/7000	112005A10
Cooling water unit DRYVAC 450/650 S	112005A12
DRYVAC 450/650 S-r	112005A13
Non-return valve DRYVAC, DN 63 ISO-K ¹⁾	112005A15
Gas ballast kit DRYVAC, 24 V electro-pneumatic	112005A17
Silencer DN 63 ISO-K for DRYVAC DV 450/650 and SCREWLINE SP 250	119002
DN 100 ISO-K for DRYVAC 1200 and SCREWLINE SP 630	119001
Serviceable silencer DN 63 ISO-K for DRYVAC DV 450/650 and SCREWLINE SP 250	119003V
DN 100 ISO-K for DRYVAC 1200 and SCREWLINE SP 630	119003V
External display (only for 650, 650-r and 1200)	155213V
Harting plug DRYVAC S-i/C-i	112005A20
Set of nozzles for DRYVAC purge gas	112005A30
Permanent inlet purge kit	112005A32

¹⁾ Already integrated in all -i/C-i versions

Only available for purchase in North and South America

General

Applications for CHEMROVAC Pumps

Pumps	TRV 404	TRV 405	TRV 406	TRV 408	TRV 410
Typical Application					
Pharmaceuticals	■	■	■	■	■
Fine chemicals	■	■	■	■	■
Flavours and fragrances	■	■	■	■	■
Fatty acids	■	■	■	■	■

General

The CHEMROVAC TRV pumps are not designed to the European ATEX directive (94/9/EC). They can therefore not be installed in Europe into flame proof

environments or be used to pump flammable materials.

This has always to be considered if you want to export these pumps into

Europe or install it in accordance to European directives and legal requirements.

Operating Principle

The CHEMROVAC TRV pumps are 4-stage roots pumps. Each stage consists of two rotors rotating in opposite directions inside a casing (pumping chamber) and having slight clearances against the inside wall surface of the casing and also between the rotors. In the sequence from (1) to (4) in the figures on this and the following page each phase of rotor rotation is shown. The light area in the figure shows inlet pressure regions of a stage whereas the slash area shows discharge pressure regions. The pumping principle of this pump is explained below, using a

cold wall type back flow mechanism, referring to left rotor in each figure.

As described above, compression takes place using the properly cooled gas of the same pressure as the discharge pressure, and therefore, the temperature rise inside the case is kept low. That means, gas discharged out of the discharge port A is cooled by the cold wall B, and a portion of this cooled gas is injected as a back flow cooling medium via the port C into the moving volume S for back flow compression. Therefore, the gas has a circulating

flow of A-B-C-S-A, and in the part of A-B-C the internal compression heat is continuously dissipated. By this a high-efficiency and a high pressure ratio are obtained.

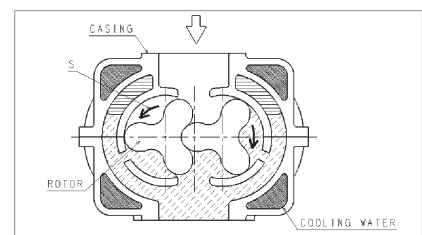

Fig. 1
This figure shows a condition just before the rotor catches the gas of the inlet pressure region into the moving volume S.

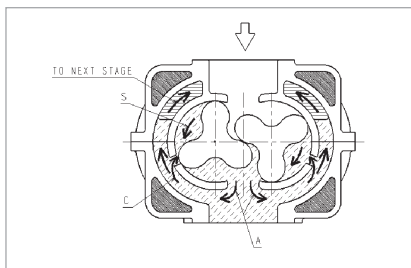

Fig. 2

In this figure, the rotor has completely caught the gas of the inlet pressure region into the moving volume S. Gas which is already discharged out at exit port A is properly cooled by the cold outside wall of the gas path B. One part of this gas flows back through the port C into the moving volume S. The other part of the cooled exhausted gas is flowing into the next stage of the pump.

Moreover, because the casing enclosing the rotors is not cooled directly, the clearances between the rotor and the casing is not reduced due to heat contraction, reducing the possibility of contact between both.

In some cases condensable gas can condense in the different stages according to its vapor pressure. Condensate either condensed in the pump or as liquid carry over from the

Advantages to the User

- Oil-free compression
- Reliable separation between swept volume and gear box side (avoiding of oil back streaming)
- Motor not on gear box side, no oil leaking by motor shaft
- Safe separation of motor and gear box area by additional shaft seal purge
- Materials of construction suitable for most chemicals to be pumped
- Flat speed curve from atmosphere to 10 mbar (7.5 Torr)
- Good liquid handling because of vertical orientation
- Easy access of swept volume for cleaning
- Easy to equip with local certified flame proof motor
- Nearly no electrical control for standard operation needed

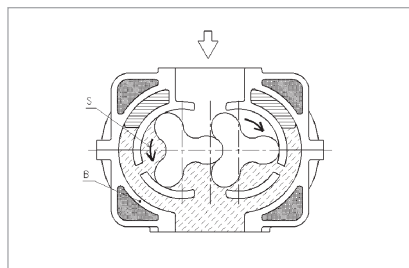

Fig. 3

As the rotor rotates further, the gas which has been cooled properly by the cold wall B flows sufficiently into the S cavity; the pressure in the chamber S is approaching the discharge pressure.

process will flow down with the gas stream and discharged to atmosphere in an exhaust drain tank.

The exhaust drain tank is mounted at the exhaust of the last pump stage. It is located either below the exhaust cooler (large pumps) or pump outlet flange (small pumps). It collects liquid condensed from the pump or the exhaust cooler.

Typical Applications

- Distillation
- Drying
- Freeze drying
- Degassing
- Central house vacuum
- Crystallisation
- Evaporation

Accessories

As standard accessory an exhaust silencer is available for each pump.

The pumps can be combined with mechanical roots blowers to increase pumping speed and to achieve lower ultimate pressure.

CHEMROVAC TRV pumps can also be the basic part of a bespoke system that complies to special process requirements to customer's needs.

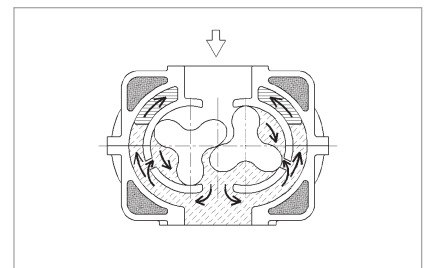

Fig. 4

In this condition the pressure in the moving volume S is approximately equal to the discharge pressure, and the discharge port A and the cavity S are just before opening to each other.

The larger pumps are equipped with a water cooled exhaust cooler as standard. The cooler is designed as shell and tube cooler. This reduces the exhaust gas temperature to an acceptable limit. Also vapors from the exhaust gas stream are partially condensed. Condensed liquid is drained into the exhaust drain tank below the condenser.

Supplied Equipment

The basic pump CHEMROVAC TRV is a pump without a motor. A suitable motor complying with the local regulations will normally be mounted by Oerlikon Leybold Vacuum. In this case the CHEMROVAC TRV is supplied ready for installation and connection.

In some cases the motor will be delivered and mounted by the end-user. In this case the user is responsible for correct selection and safe mounting of the motor. OLV will not take over any responsibility for the motor and motor mounting in such a case.

The electrical connections to the pump must be provided by suitably trained staff of the customer.

The basic CHEMROVAC TRV pump is delivered with:

- Nitrogen shaft seal purge unit
- The required amount of gear oil (is supplied separately)
- 2 crane eyes for transporting the pump
- Operating Instructions

Products

CHEMROVAC TRV 404 to 410

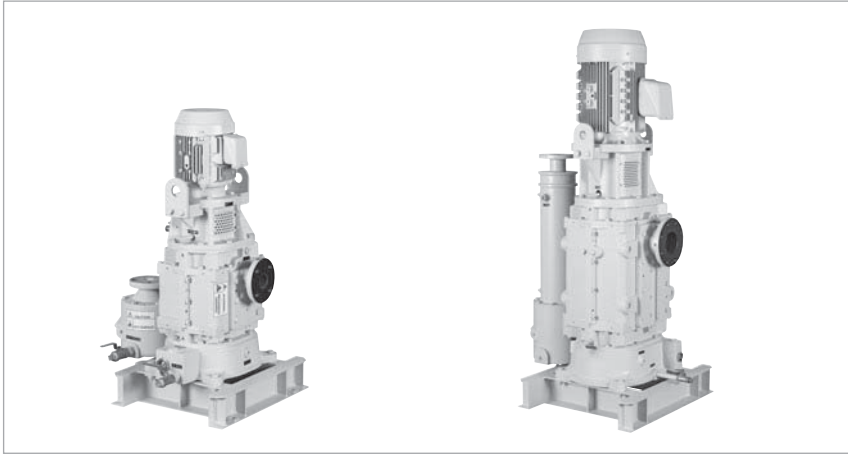

CHEMROVAC TRV 404 (left) and TRV 410 (right)

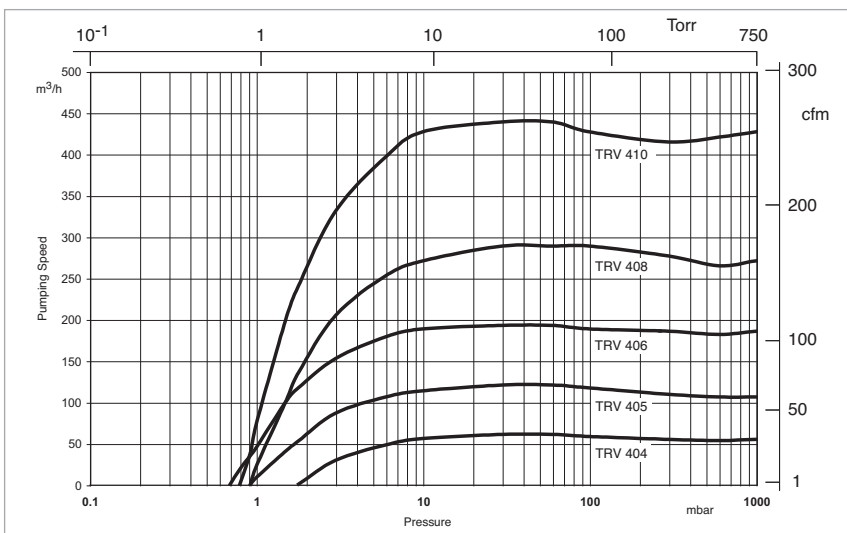

Pumping speed curves for the CHEMROVAC TRV at 50 Hz

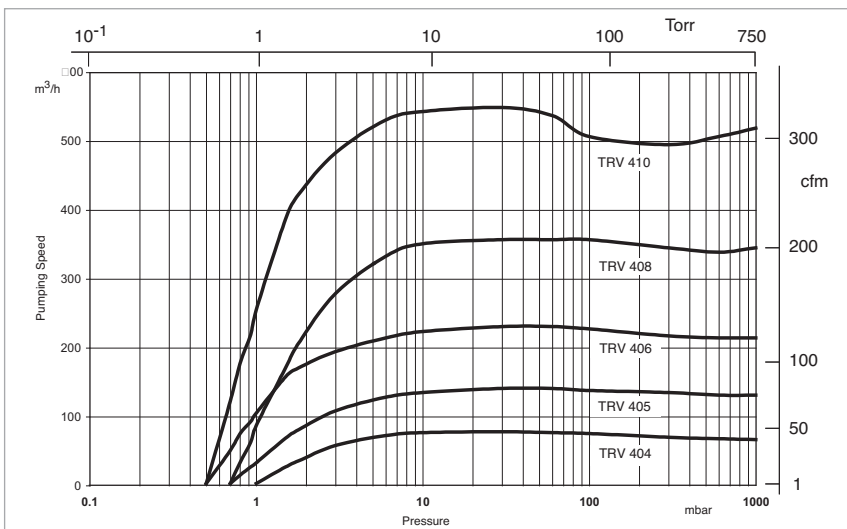

Pumping speed curves for the CHEMROVAC TRV at 60 Hz

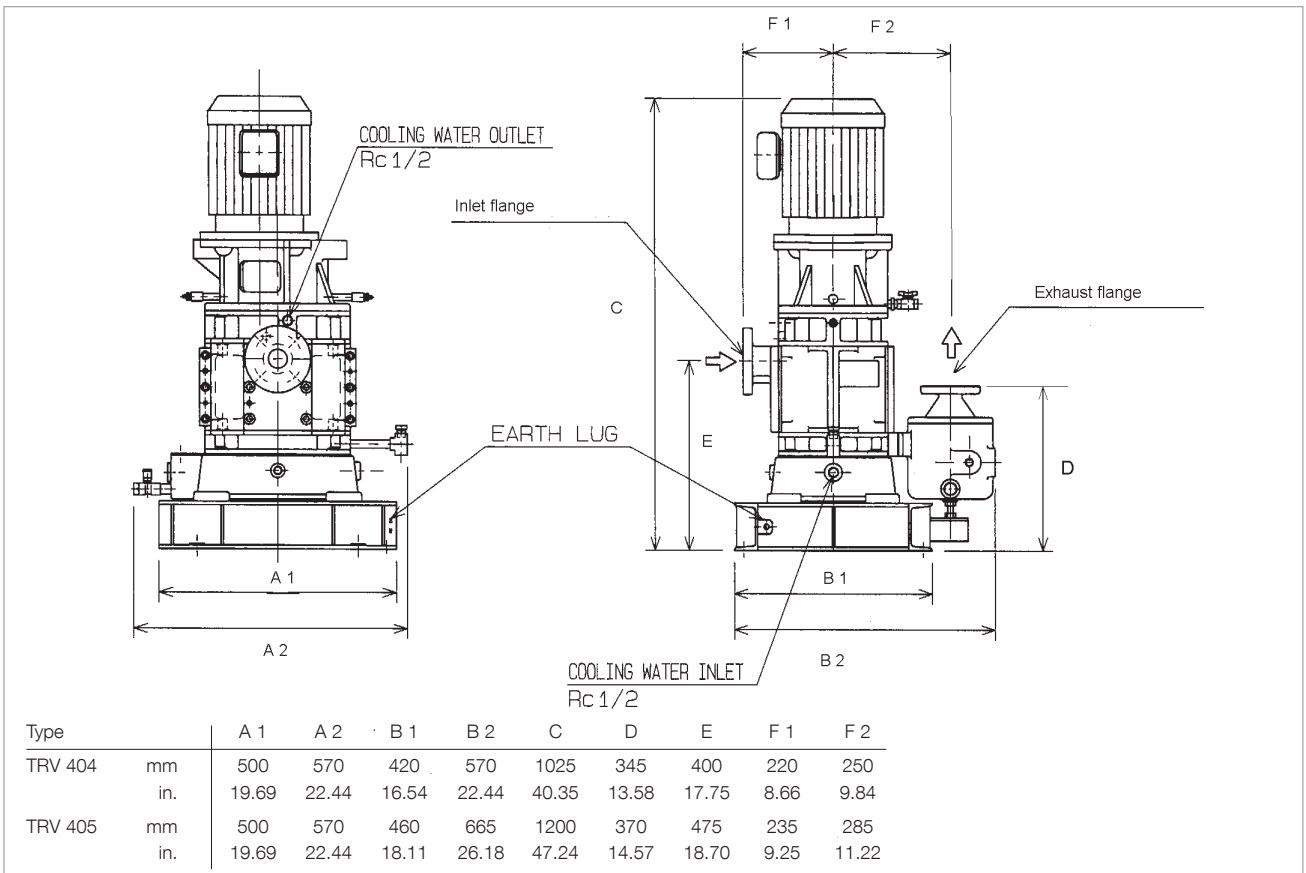

Dimensional drawing of the CHEMROVAC TRV 404 and 405

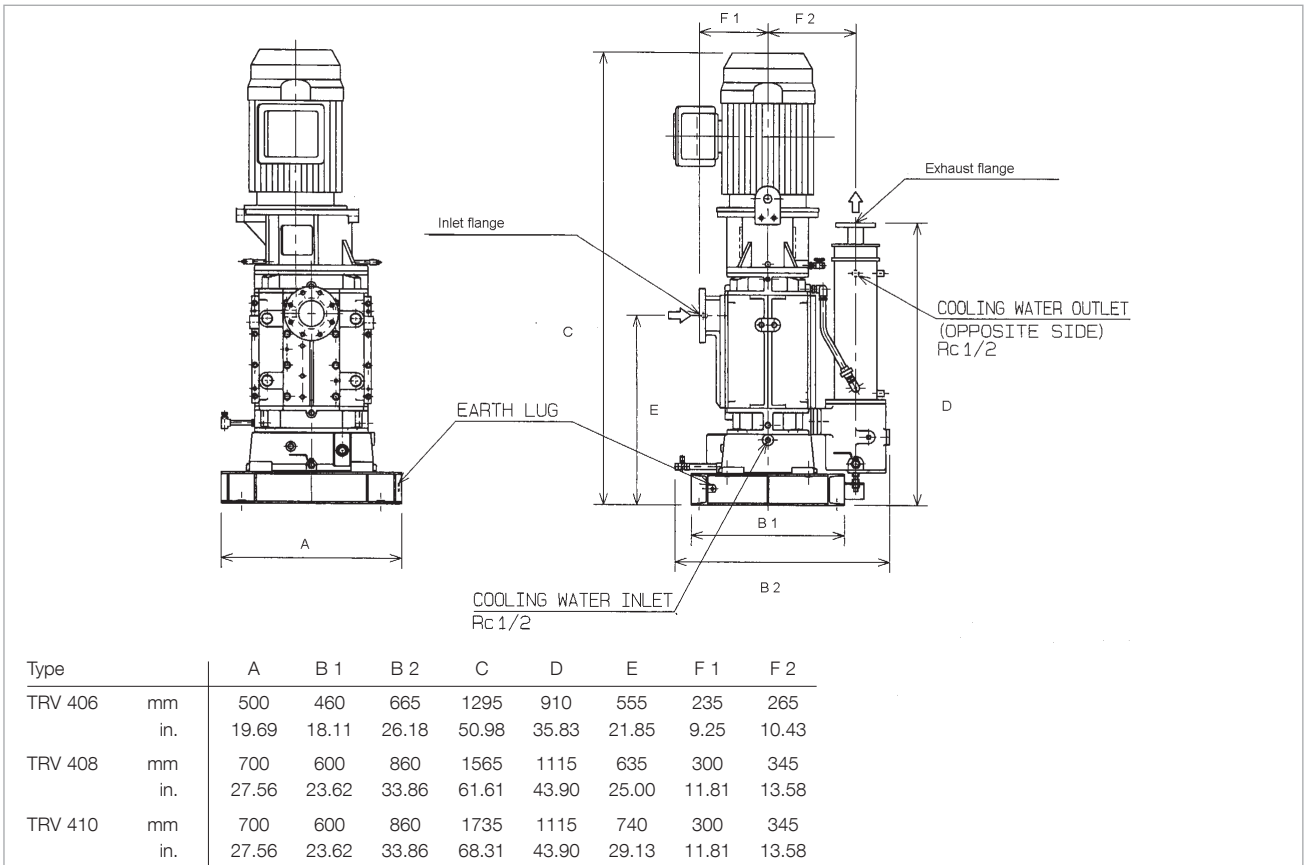

Dimensional drawing of the CHEMROVAC TRV 406 to 410

Technical Data

CHEMROVAC

		TRV 404	TRV 405	TRV 406	TRV 408	TRV 410
Max. pumping speed (+/- 10%)						
60 Hz	m ³ x h ⁻¹ (cfm)	75 (44)	138 (81)	228 (134)	354 (208)	546 (321)
50 Hz	m ³ x h ⁻¹ (cfm)	60 (36)	120 (71)	192 (113)	288 (170)	438 (258)
Ultimate total pressure, abs.						
60 Hz	mbar (Torr)	1.0 (0.75)	0.7 (0.53)	0.5 (0.38)	0.7 (0.53)	0.5 (0.38)
50 Hz	mbar (Torr)	1.8 (1.35)	0.9 (0.68)	0.7 (0.53)	0.9 (0.68)	0.8 (0.60)
Max. permissible exhaust back pressure, abs.	mbar (Torr)	1200 (900)	1200 (900)	1200 (900)	1200 (900)	1200 (900)
Max. permissible inlet pressure, abs.	mbar (Torr)	1050 (788)	1050 (788)	1050 (788)	1050 (788)	1050 (788)
Max. permissible inlet temperature	°C (°F)	50 (122)	50 (122)	50 (122)	50 (122)	50 (122)
Permissible ambient temperature for constant operation ¹⁾	°C (°F)	-20 to +40 (-4 to +104)	-20 to +40 (-4 to +104)	-20 to +40 (-4 to +104)	-20 to +40 (-4 to +104)	-20 to +40 (-4 to +104)
Max. relative ambient moisture	%	up to 90	up to 90	up to 90	up to 90	up to 90
Max. permissible installation height	m (ft)	up to 1000 (up to 3280)	up to 1000 (up to 3280)	up to 1000 (up to 3280)	up to 1000 (up to 3280)	up to 1000 (up to 3280)
Noise level with silencer at ultimate (± 3 dB(A))						
60 Hz	dB(A)	76	79	81	81	82
50 Hz	dB(A)	73	75	77	78	79
Process flange size						
inlet	ANSI / lb ff	1 1/2" / 125	2" / 125	2 1/2" / 125	3" / 125	4" / 125
outlet	ANSI / lb ff	1 1/2" / 125	1 1/2" / 125	2 1/2" / 150	2 1/2" / 150	2 1/2" / 150
Cooling water flange size						
inlet	Rc	1/2"	1/2"	1/2"	1/2"	1/2"
outlet	Rc	1/2"	1/2"	1/2"	1/2"	1/2"
Shaft seal purge gas connection	Rc	3/8"	3/8"	3/8"	3/8"	3/8"
Recommended shaft seal purge flow						
gear side	l/min (gallon/min)	3.0 (0.8)	5.0 (1.3)	5.0 (1.3)	6.0 (1.6)	6.0 (1.6)
motor side	l/min (gallon/min)	0,5 (0.15)	1.0 (0.3)	1.0 (0.3)	2.0 (0.6)	2.0 (0.6)
Type of gas, shaft seal purge		Nitrogen	Nitrogen	Nitrogen	Nitrogen	Nitrogen
Supply pressure, shaft seal purge	bar / psi abs.	2 / 29	2 / 29	2 / 29	2 / 29	2 / 29
Dew point of supply gas	°C (°F)	-15 (+5)	-15 (+5)	-15 (+5)	-15 (+5)	-15 (+5)
Maximum particle size in gas	µm	3	3	3	3	3
Weight without motor	kg (lbs)	180 (397)	235 (520)	280 (617)	535 (1180)	590 (1300)
Assumed weight with motor	kg (lbs)	235 (520)	319 (705)	396 (875)	708 (1560)	816 (1800)

¹⁾ If you operate the pump in an ambient temperature between -20 and +5 °C (-4 to +41 °F) we recommend that you leave the pump constantly operating and only shut down the pump for maintenance purposes. The pump must be pre-warmed if you want to start it in an ambient temperature range between -20 and +5 °C (-4 to +41 °F).

Additional Technical Data
CHEMROVAC

		TRV 404	TRV 405	TRV 406	TRV 408	TRV 410
Motor flame proof protection		to local standards, e.g. class 1, division 1, C&D, or Ex d IIB				
Start-up method		direct on line or via frequency converter				
Voltage	V	depending on local requirements				
Installed power						
60 Hz	kW (HP)	3.7 (5.0)	5.5 (7.5)	7.5 (10.0)	15.0 (20.0)	18.5 (25.0)
50 Hz	kW (HP)	3.7 (5.0)	5.5 (7.5)	7.5 (10.0)	15.0 (20.0)	18.5 (25.0)
Absorbed power at ultimate pressure						
60 Hz	kW (HP)	2.1 (2.8)	3.3 (4.4)	4.8 (6.4)	9.0 (12.1)	12.5 (16.8)
50 Hz	kW (HP)	1.8 (2.4)	3.0 (4.0)	4.1 (5.5)	7.0 (9.4)	10.0 (13.4)
Motor frame size	NEMA IEC	184TC 112 M	213TC 132 S	215TC 132 S	256TC 160 M	284TSC 160 L
No. of phases		3	3	3	3	3
No. of poles		2	2	2	2	2
Motor frequency	Hz	50 or 60, depending on local conditions				
Operating frequency	Hz	26 to 60				
Nominal revolution	1/min	3000 or 3600, depending on motor frequency				
Cooling		water, direct without temperature control valve				
Minimum cooling water consumption (at 25 °C (77 °F) inlet temperature)						
60 Hz	l/min (gallon/min)	5.0 (1.3)	7.0 (1.9)	10.0 (2.7)	20.0 (5.3)	28.0 (7.4)
50 Hz	l/min (gallon/min)	5.0 (1.3)	7.0 (1.9)	10.0 (2.7)	20.0 (5.3)	28.0 (7.4)
Cooling water temperature	°C (°F) °C (°F)	+10 to +35 (+50 to +95)	+10 to +35 (+50 to +95)	+10 to +35 (+50 to +95)	+10 to +35 (+50 to +95)	+10 to +35 (+50 to +95)
Cooling water supply pressure, abs.	bar (psi)	3 to 7 (44 to 102)	3 to 7 (44 to 102)	3 to 7 (44 to 102)	3 to 7 (44 to 102)	3 to 7 (44 to 102)
Lubrication bearing motor side (grease) gear side (oil)	ml	100	200	200	260	260
		depends on oil capacity				
Oil type for gear box		LVO 130	LVO 130	LVO 130	LVO 130	LVO 130
Volume gear box oil	l (gallon)	1.0 (0.3)	1.0 (0.3)	1.0 (0.3)	4.0 (1.1)	4.0 (1.1)

Ordering Information
CHEMROVAC

		TRV 404	TRV 405	TRV 406	TRV 408	TRV 410
		Part No.	Part No.	Part No.	Part No.	Part No.
Dry vacuum pump for chemical and pharmaceutical application CHEMROVAC TRV (without motor)		134 101	134 102	134 103	134 104	134 105
CHEMROVAC TRV (with NEMA motor Class 1, Div. 1, Group C & D, 406/460 V, 60 Hz)		134 201 V	134 202 V	134 203 V	134 204 V	134 205 V
Accessories Exhaust silencer, filled with mineral wool		134 121	134 121	134 122	134 122	134 122

Sales and Service

Germany

Oerlikon Leybold Vacuum GmbH
Sales, Service, Support Center (3SC)
Bonner Strasse 498
D-50968 Cologne
Phone: +49-(0)221-347 1234
Fax: +49-(0)221-347 31234
sales.vacuum@oerlikon.com
www.oerlikon.com/leyboldvacuum

Oerlikon Leybold Vacuum GmbH
Sales Area North
Branch Office Berlin
Industriestrasse 10b
D-12099 Berlin
Phone: +49-(0)30-435 609 0
Fax: +49-(0)30-435 609 10
sales.vacuum.bn@oerlikon.com

Oerlikon Leybold Vacuum GmbH
Sales Office South
Branch Office Munich
Karl-Hammerschmidt-Strasse 34
D-85609 Aschheim-Dornach
Phone: +49-(0)89-357 33 9-10
Fax: +49-(0)89-357 33 9-33
sales.vacuum.mn@oerlikon.com
service.vacuum.mn@oerlikon.com

Oerlikon Leybold Vacuum
Dresden GmbH
Service Competence Center
Zur Wetterwarte 50, Haus 304
D-01109 Dresden
Service:
Phone: +49-(0)351-88 55 00
Fax: +49-(0)351-88 55 041
info.vacuum.dr@oerlikon.com

Europe

Belgium

Oerlikon Leybold Vacuum
Nederland B.V.
Belgisch bijkantoor
Leuvensesteenweg 542-9A
B-1930 Zaventem
Sales:
Phone: +32-2-711 00 83
Fax: +32-2-720 83 38
sales.vacuum.zv@oerlikon.com
Service:
Phone: +32-2-711 00 82
Fax: +32-2-720 83 38
service.vacuum.zv@oerlikon.com

France

Oerlikon Leybold Vacuum
France S.A.S.
Parc du Technopolis, Bâtiment Beta
3, Avenue du Canada
F-91940 Les Ulis cedex
Sales and Service:
Phone: +33-1-69 82 48 00
Fax: +33-1-69 07 57 38
info.vacuum.ctb@oerlikon.com
sales.vacuum.ctb@oerlikon.com

Oerlikon Leybold Vacuum
France S.A.S.
Valence Factory
640, Rue A. Bergès
B.P. 107
F-26501 Bourg-lès-Valence Cedex
Phone: +33-4-75 82 33 00
Fax: +33-4-75 82 92 69
marketing.vacuum.vc@oerlikon.com

Great Britain

Oerlikon Leybold Vacuum
UK LTD.
Unit 9
Silverglade Business Park
Leatherhead Road
Chessington
Surrey (London)
KT9 2QL
Sales:
Phone: +44-13-7273 7300
Fax: +44-13-7273 7301
sales.vacuum.ln@oerlikon.com
Service:
Phone: +44-13-7273 7320
Fax: +44-13-7273 7303
service.vacuum.ln@oerlikon.com

Italy

Oerlikon Leybold Vacuum
Italia S.r.l.
Via Trasimeno 8
I-20128 Mailand
Sales:
Phone: +39-02-27 22 31
Fax: +39-02-27 20 96 41
sales.vacuum.mi@oerlikon.com
Service:
Phone: +39-02-27 22 31
Fax: +39-02-27 22 32 17
service.vacuum.mi@oerlikon.com

Netherlands

Oerlikon Leybold Vacuum
Nederland B.V.
Floridadreef 102
NL-3565 AM Utrecht
Sales and Service:
Phone: +31-(30) 242 63 30
Fax: +31-(30) 242 63 31
sales.vacuum.ut@oerlikon.com
service.vacuum.ut@oerlikon.com

Switzerland

Oerlikon Leybold Vacuum
Schweiz AG, Pfäffikon
Churerstrasse 120
CH-8808 Pfäffikon
Warehouse and shipping address:
Riedthofstrasse 214
CH-8105 Regensdorf
Sales:
Phone: +41-44-308 40 50
Fax: +41-44-302 43 73
sales.vacuum.zh@oerlikon.com
Service:
Phone: +41-44-308 40 62
Fax: +41-44-308 40 60
service.vacuum.zh@oerlikon.com

Spain

Oerlikon Leybold Vacuum
Spain, S.A.
C/. Huelva, 7
E-08940 Cornellà de Llobregat
(Barcelona)
Sales:
Phone: +34-93-666 43 11
Fax: +34-93-666 43 70
sales.vacuum.ba@oerlikon.com
Service:
Phone: +34-93-666 46 11
Fax: +34-93-685 43 70
service.vacuum.ba@oerlikon.com

America

USA

Oerlikon Leybold Vacuum
USA Inc.
5700 Mellon Road
USA-Export, PA 15632
Phone: +1-724-327-5700
Fax: +1-724-325-3577
info.vacuum.ex@oerlikon.com
Sales:
Phone: +1-724-327-5700
Fax: +1-724-333-1217
Service:
Phone: +1-724-327-5700
Fax: +1-724-325-3577

Brazil

Oerlikon Leybold Vacuum
Brasil
Rod. Vice-Prefeito Hermenegildo Tonolli,
nº. 4413 - 6B
Distrito Industrial
Jundiá - SP
CEP 13.212-315
Sales and Service:
Phone: +55 11 2152 0499
Fax: +55 11 99467 5934
sales.vacuum.ju@oerlikon.com
service.vacuum.ju@oerlikon.com

Asia

P. R. China

Oerlikon Leybold Vacuum (Tianjin)
International Trade Co. Ltd.
Beichen Economic
Development Area (BEDA),
No. 8 Western Shuangchen Road
Tianjin 300400
China
Sales and Service:
Phone: +86-22-2697 0808
Fax: +86-22-2697 4061
Fax: +86-22-2697 2017
sales.vacuum.tj@oerlikon.com
service.vacuum.tj@oerlikon.com

India

Oerlikon Leybold Vacuum
India Pvt Ltd.
No. 82(P), 4th Phase
K.I.A.D.B. Plot
Bommasandra Industrial Area
Bangalore - 560 099
Indien
Sales and Service:
Phone: +91-80-2783 9925
Fax: +91-80-2783 9926
sales.vacuum.bgl@oerlikon.com
service.vacuum.bgl@oerlikon.com

Japan

Oerlikon Leybold Vacuum
Japan Co., Ltd.
Headquarters
Shin-Yokohama A.K.Bldg., 4th floor
3-23-3, Shin-Yokohama
Kohoku-ku, Yokohama-shi
Kanawaga 222-0033
Japan
Sales:
Phone: +81-45-471-3330
Fax: +81-45-471-3323
info.vacuum.yh@oerlikon.com
sales.vacuum.yh@oerlikon.com

Oerlikon Leybold Vacuum

Japan Co., Ltd.
Tsukuba Technical Service Center
1959, Kami-yokoba
Tsukuba-shi, Ibaraki-shi 305-0854
Japan
Service:
Phone: +81-29 839 5480
Fax: +81-29 839 5485
service.vacuum.iik@oerlikon.com

Malaysia

Oerlikon Leybold Malaysia
Oerlikon Leybold Vacuum
Singapore Pte Ltd.
No. 1 Jalan Hi-Tech 2/6
Kulim Hi-Tech Park
Kulim, Kedah Darul
Aman 09000
Malaysia
Sales and Service:
Phone: +604 4020 222
Fax: +604 4020 221
sales.vacuum.ku@oerlikon.com
service.vacuum.ku@oerlikon.com

South Korea

Oerlikon Leybold Vacuum
Korea Ltd.
3F. Jellzone 2 Tower
Jeongja-dong 159-4
Bundang-gu Sungnam-si
Gyeonggi-do
Bundang 463-384, Korea
Sales:
Phone: +82-31 785 1367
Fax: +82-31 785 1359
sales.vacuum.bd@oerlikon.com
Service:
623-7, Ulsung-Dong
Cheonan-Si
Chungcheongnam-Do
Korea 330-290
Phone: +82-41 589 3035
Fax: +82-41 588 0166
service.vacuum.cn@oerlikon.com

Singapore

Oerlikon Leybold Vacuum
Singapore Pte Ltd.
8 Commonwealth Lane #01-01
Singapore 149555
Singapore
Sales and Service:
Phone: +65-6303 7030
Fax: +65-6773 0039
sales.vacuum.sg@oerlikon.com
service.vacuum.sg@oerlikon.com

Taiwan

Oerlikon Leybold Vacuum
Taiwan Ltd.
No 416-1, Sec. 3
Chunghsin Rd., Chutung
Hsinchu County 310
Taiwan, R.O.C.
Sales and Service:
Phone: +886-3-500 1688
Fax: +886-3-583 3999
sales.vacuum.hc@oerlikon.com
service.vacuum.hc@oerlikon.com

Oerlikon
Leybold Vacuum GmbH
Bonner Strasse 498
D-50968 Cologne
Phone: +49-(0)221-347 0
Fax: +49-(0)221-347 1250
info.vacuum@oerlikon.com

oerlikon
leybold vacuum
www.oerlikon.com/
leyboldvacuum